

Parts List 277/278 Series

Effective: March 15, 2011

Supersedes: HY25-2277-M1/US June 15, 2010

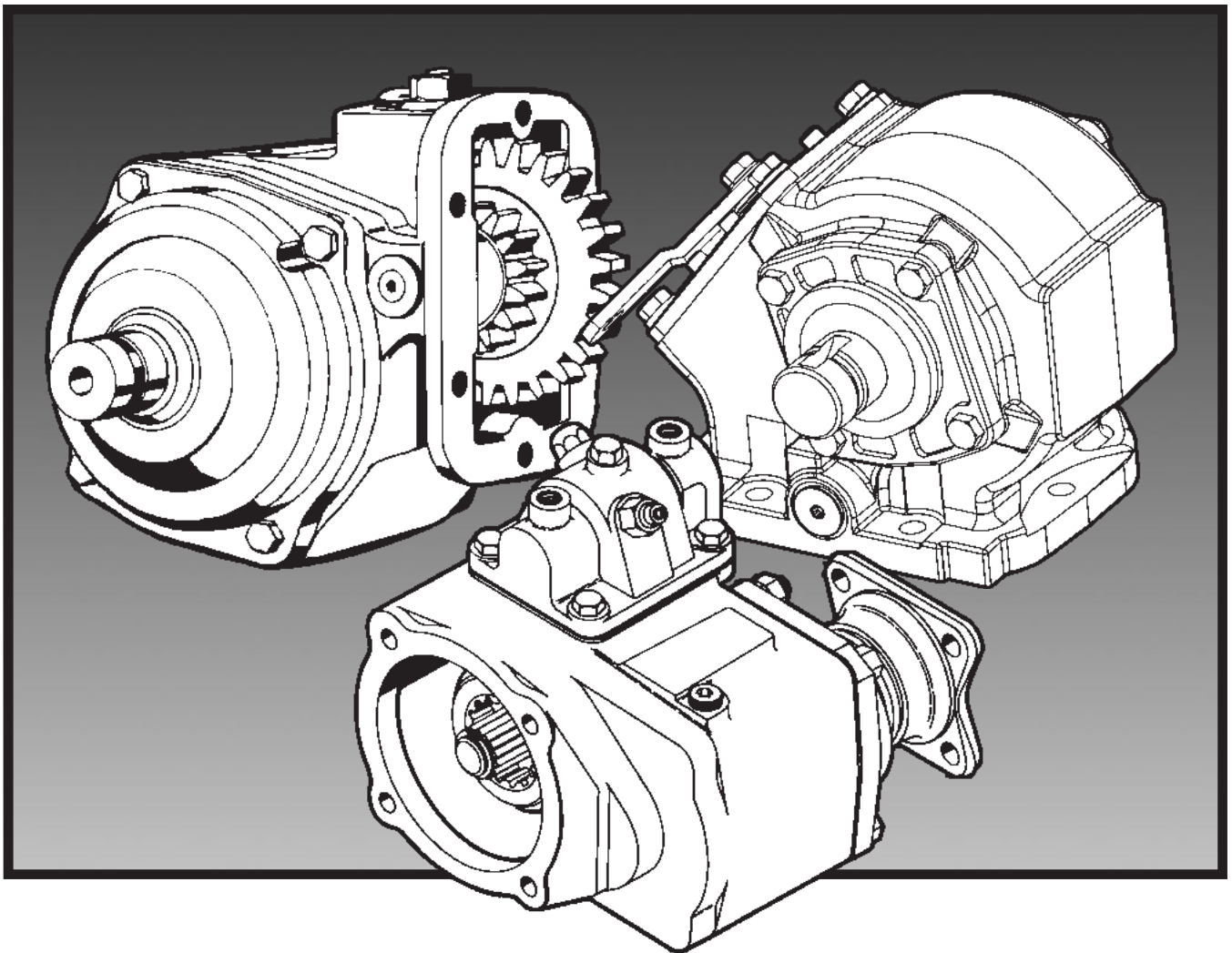

 **WARNING**

FAILURE OR IMPROPER SELECTION OR IMPROPER USE OF THE PRODUCTS AND/OR SYSTEMS DESCRIBED HEREIN OR RELATED ITEMS CAN CAUSE DEATH, PERSONAL INJURY AND PROPERTY DAMAGE.

This document and other information from Parker Hannifin Corporation, its subsidiaries and authorized distributors provide product and/or system options for further investigation by users having technical expertise. It is important that you analyze all aspects of your application and review the information concerning the product or system in the current product catalog. Due to the variety of operating conditions and applications for these products or systems, the user, through its own analysis and testing, is solely responsible for making the final selection of the products and systems and assuring that all performance, safety and warning requirements of the application are met.

The products described herein, including without limitation, product features, specifications, designs, availability and pricing, are subject to change by Parker Hannifin Corporation and its subsidiaries at any time without notice.

Offer of Sale

The items described in this document are hereby offered for sale by Parker Hannifin Corporation, its subsidiaries or its authorized distributors. This offer and its acceptance are governed by the provisions stated in the "Offer of Sale".

© Copyright 2010, Parker Hannifin Corporation, All Rights Reserved

Contents

277 Exploded View	1
277 Bill of Materials	2-4
277 Gear Chart.....	4
277 Series Output Shafts	5
277 Model Number Designation	6
277 P.T.O. Housing Dimensions.....	6
278 Exploded View	7
278 Bill of Materials	8-10
278 Gear Chart.....	10
278 Series Output Shafts	11
278 Model Designation.....	12
278 P.T.O. Housing Dimensions.....	12
Valve and Cap Assembly Bill of Materials	13
277/278 Pump Flange & Shaft Dimensions.....	14
Bill of Material “BA” Option	15
Pump Flange Conversion Kits Bills of Materials.....	16-21
“ZY” Wet Spline Installation Sketch (SK-454 Rev A)	22
P.T.O. Combo Valve Installation Sketch (SK-427 Rev C)	23
Allison	
Shift Installation Sketch without E.O.C. (SK-347 Rev D).....	24
Shift Installation Sketch with E.O.C. (SK-348 Rev C).....	24
Shift Installation Sketch with Remote Mount Solenoid (SK-432 Rev B).....	25
Hino	
Shift Installation Sketch with Remote Mount Solenoid for Model 338 (SK-410 Rev B)	25
Caterpillar	
Shift Installation Sketch without E.O.C. (SK-411 Rev A).....	26
Shift Installation Sketch with E.O.C. (SK-473).....	26
Remote Mount Installation Sketch (SK-413 Rev C)	27
“AF” Wet Spline Installation Sketch (SK-383 Rev C)	27
Caterpillar Pressure Port Location and Hose Chart	28
Allison Pressure Port and Aperture Opening Identification	29
Offer of Sale	32

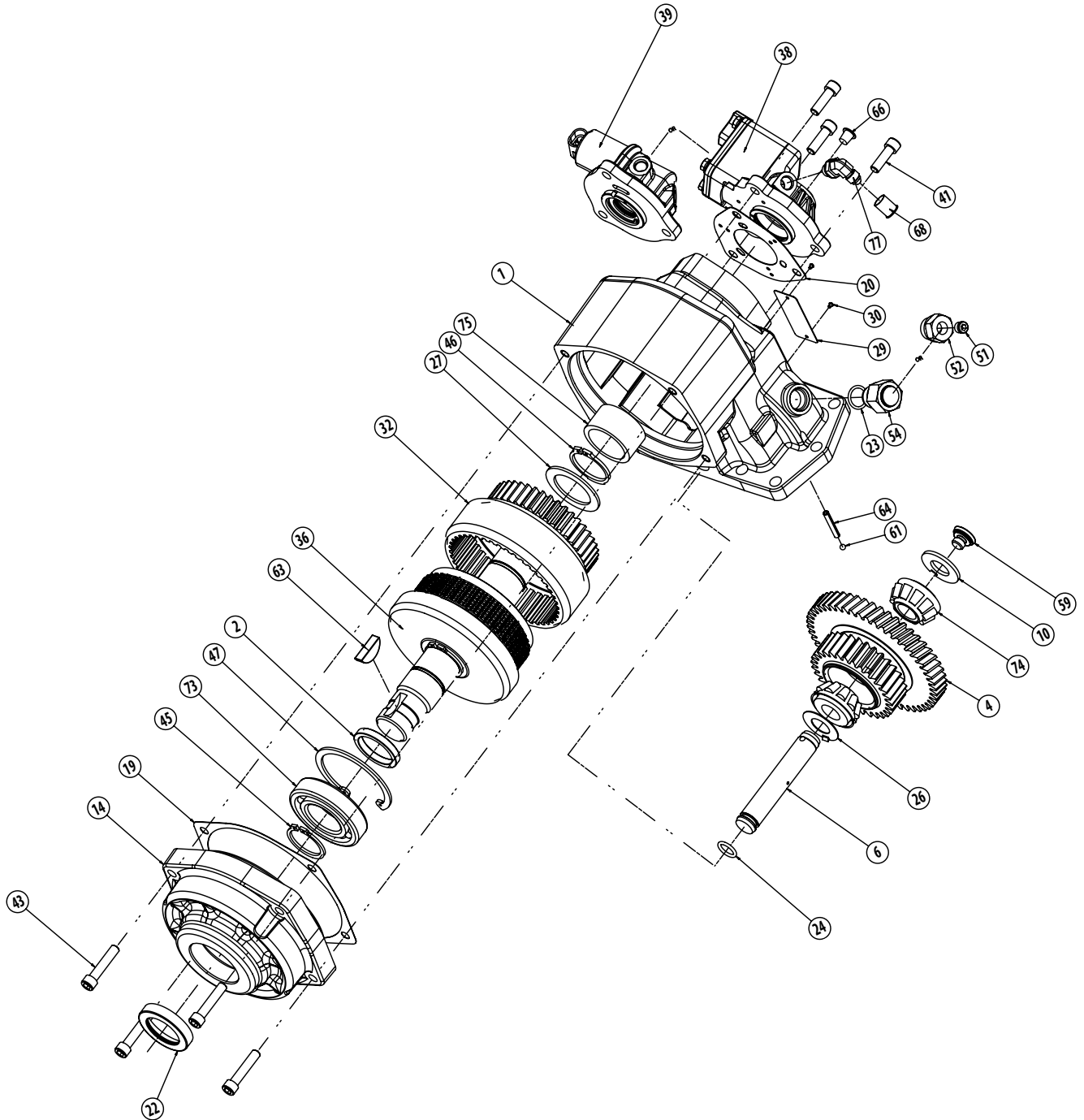

Item	Part Number	Description	Quantity
1	1-P-603	P.T.O. Housing	1
2	4-P-147 4-P-187	Spacer, Drive Shaft..... Spacer, ("ZY" Output)	1 1 or
4	See Page 4	Input Gear.....	1
6	9-P-91	Idler Shaft	1
10	14-P-79-1 14-P-79-2 14-P-79-3 14-P-79-4	Tabbed Washer (.112"-.114")..... Tabbed Washer (.116"-.118") Tabbed Washer (.120"-.122") Tabbed Washer (.124"-.126")	A.R.
14	See Below 21-P-480 21-P-691 See Pages 16-21	Bearing Cover (open)..... Bearing Cover ("XD" Output) Bearing Cover "BA" Only ("BA" Output) Bearing Cover (All Other Outputs)	1
19	22-P-101 22-P-101	Gasket Bearing Cap ("BA" Output)..... Gasket Bearing Cap (All other Outputs).....	2 or 1
20	22-P-112	Gasket, Valve Cap	1
22	See Below 28-P-225 See Pages 16-21	Oil Seal..... Oil Seal (Output Side) ("XD" Output) Oil Seal (Output Side) (All Other Outputs)	1
23	28-P-171	O-Ring (With E.O.C. Only).....	1
24	28-P-191	O-Ring	1
26	31-P-102	Thrust Washer	1
27	31-P-70	Thrust Washer	1
29	68-P-2	Name Plate.....	1
30	378422	Drive Screw	2
32	See Page 4	Output Gear Sub Assembly.....	1
N.S.	560972	Bearing	1
N.S.	329252X 329403X	Seal Cap Assembly (Hino Mount Only)..... Seal Cap Assembly ("G" & "H" Shift Only).....	1 or 1
36	See Below 329006-1X 329006-10X See Page 5	Drive Shaft & Clutch Ass'y..... Drive Shaft & Clutch Ass'y (3-P-831) ("XD" Output) Drive Shaft & Clutch Ass'y (3-P-985) ("BA" Output) Drive Shaft & Clutch Ass'y (All Other Outputs)	1
38	See Page 13 329352-12X 329352-24X	Valve & Valve Cap Assembly (12V) "Old Style" ("FJ" Pitch Only)..... Valve & Valve Cap Assembly (24V) "Old Style" ("FJ" Pitch Only).....	1 or 1 or
39	329442-12X 329442-24X 329463-12X 329463-24X	Valve & Valve Cap Assembly (12V) ("KV" Pitch Only)..... Valve & Valve Cap Assembly (24V) ("KV" Pitch Only)..... Valve & Valve Cap Assembly (12V) ("FJ" Pitch Only)..... Valve & Valve Cap Assembly (24V) ("FJ" Pitch Only).....	1 or 1 or 1 or 1
41	378447-6	Hex. Capscrew Soc. Hd. Capscrew .312"-18 x 1.00".....	3
43	378447-16 378447-8	Soc. Hd. Capscrew .312"-18 x 3.50" ("BA" Output)..... Soc. Hd. Capscrew .312"-18 x 1.50" (All other Outputs).....	4 or 4
45	378576 379555 378576	Retaining Ring ("BA" Output)..... Retaining Ring ("ZY" Output)..... Retaining Ring (All Other Outputs).....	2 or 1 or 1
46	379746	Retaining Ring	1

A.R.—As Required N.S.—Not Shown

Continued on Next Page

Item	Part Number	Description	Quantity
47	378895 378263	Retaining Ring1 or Retaining Ring ("ZY" Output).....1	
51	379231	Pipe Plug .125"-27 NPTF (Without E.O.C. Only).....1	
52	379242	O-Ring Boss Plug (Without E.O.C. Only).....1	
54	379243	Speed Sensor (With E.O.C. Only)1	
59	379672	NWD Plug.....1	
60	379486	Straight Thread Connector 90°1 or	
	379556	Straight Thread O-Ring Run Tee ("ZY" Output)1	
61	378108	Ball1	
63	500007-29	Woodruff Key ("XD" & "BA" Outputs)1	
64	500597-16	Spring Pin.....1	
66	500897-3	Shipping Plug1	
68	379564-2	Shipping Cap ("G" & "H" Shift Options).....3 Shipping Cap (All Other Shift Options).....1	
73	550010	Ball Bearing1 or	
	550311	Ball Bearing ("ZY" Output)1	
74	550439	Tapered Bearing Cone.....2	
75	560972	Needle Bearing.....1	
		Loose Parts	
	328748X	Pump Mounting Kit (For "XR" Output Only)1	
	7170-86X	Stud Kit ("FJ" Gear Pitch)1	
	379451	Guide Screw2	
	379453-10	Ferry Capscrew (M10-1.5"x 35mm)8	
	379486	90° Elbow Fitting w/O-Ring (Transmission High Pressure)1	
	328948-9X	Gasket & Installation Instructions1	
	See Below	Installation Kit1	
	329237-12X	Installation Kit 12V Remote Valve w/o E.O.C.	
	329237-24X	Installation Kit 24V Remote Valve w/o E.O.C.	
	329024-12X	Installation Kit 12V (Less E.O.C.)	
	329024-24X	Installation Kit 24V (Less E.O.C.)	
	329076X	Installation Kit 12V & 24V (With E.O.C.)	
	329443-12X	Installation Kit 12V ("KV" Pitch Only)	
	329443-24X	Installation Kit 24V ("KV" Pitch Only)	
	329444X	Installation Kit 12V & 24V (With E.O.C.) ("KV" Pitch Only)	
	329445-12X	Installation Kit 12V Remote Valve ("KV" Pitch Only)	
	329445-24X	Installation Kit 24V Remote Valve ("KV" Pitch Only)	
	7170-117X	Stud Kit ("KV" Input Gear)1	
	379451	Guide Screw2	
	379453-10	Ferry Capscrew (M10-1.5" x 35mm)8	
	379812	Straight Thread O-Ring Connector (7/16"-24)1	
	328924-12X	Control Box 12V (With E.O.C.)1 or	
	328924-24X	Control Box 24V (With E.O.C.)1	
	328388-85X	Airshift Installation Kit "S" Shift Option1	
	328388-86X	Airshift Installation Kit "T" Shift Option1	
	329441X	Pressure Switch Relocation Kit (Hino) (For "HINO" Mount)	
	329130-1X	Hose Assembly (For "HINO" Only)	
	329057-4X	Hose Assembly ("G" & "H" Shift Only)1	
	328075X	Hose Assembly ("G" & "H" Shift Only)1	
		Service Kits	
	329277-1X	Complete Installation Kit 21V (less E.O.C.) for "B" Shift Only. Shipped w/Unit	
	1-P-603X	P.T.O. Housing w/ Spring Pin	
	329071-19X	Gasket & Seal Kit	

A.R.—As Required N.S.—Not Shown

Continued on Next Page

Item	Part Number	Description	Quantity
		Service Kits (Continued)	
	329071-33X	Gasket & Seal Kit (For "XY" Output Only)	
	329071-36X	Bearing Kit	
	329071-43X	Gasket & Seal Kit ("ZY" Output)	
	329071-44X	Bearing Kit ("ZY" Output)	
	329071-45X	Clutch Repair Kit ("ZY" Output)	
	329071-7X	Clutch Repair Kit	
	329175-12X	E.O.C. Field Conversion Kit 12V	
	329175-24X	E.O.C. Field Conversion Kit 24V	
	329354-12X	Conversion Kit 12V Remote Mount Valve	
	329354-24X	Conversion Kit 24V Remote Mount Valve	
	329160-59X	Conversion Kit "XD" to "BA" (Reference Page 15)	
	329043-21X	Service Kit "BA" Brake Section Only	
	329071-35X	Gasket & Seal Kit, "BA"	
	329447-12X	Kit Remote Valve Conversion 12V ("KV" Pitch Only)	
	329447-24X	Kit Remote Valve Conversion 24V ("KV" Pitch Only)	
	329448-12X	Kit E.O.C. Field Conversion 12V ("KV" Pitch Only)	
	329448-24X	Kit E.O.C. Field Conversion 24V ("KV" Pitch Only)	

277 Gear Chart

Model Number	Input Gear Part Number Item No. 4	Number Teeth Lg/Sm	Output Gear Item No. 32		Gear & Bearing* Sub-assembly Items 32
			Part Number	Number Teeth	
277XBFJ	5-P-912	50/25	2-P-688	47	329005-1X
277XDFJ	5-P-913	50/28	2-P-684	44	329005-2X
277XGFJ	5-P-914	50/31	2-P-683	41	329005-3X
277XMFJ	5-P-915	50/35	2-P-682	37	329005-4X
277XSFJ	5-P-1173	50/39	2-P-756	33	329005-5X
SUPER TORQUE™					
277SBFJ	5-P-1350	50/25	2-P-800	47	329005-6X
277SDFJ	5-P-1293	50/28	2-P-790	44	329005-7X
277SGFJ	5-P-1225	50/31	2-P-779	41	329005-8X
277SMFJ	5-P-1351	50/35	2-P-801	37	329005-9X
277SSFJ	5-P-1278	50/39	2-P-789	33	329005-10X
277XBKV	5-P-1361	45/25	2-P-688	47	329005-1X
277XDKV	5-P-1362	45/28	2-P-684	44	329005-2X
277XGKV	5-P-1363	45/31	2-P-683	41	329005-3X
277XMKV	5-P-1367	45/35	2-P-682	37	329005-4X
277XSKV	5-P-1369	45/39	2-P-756	33	329005-5X
SUPER TORQUE™					
277SBKV	5-P-1402	45/25	2-P-800	47	329005-6X
277SDKV	5-P-1413	45/28	2-P-790	44	329005-7X
277SGKV	5-P-1414	45/31	2-P-779	41	329005-8X
277SMKV	5-P-1415	45/35	2-P-801	37	329005-9X
277SSKV	5-P-1416	45/39	2-P-789	33	329005-10X

*Bearing Part Number 560972

277 Series Output Shafts & Clutch Assembly Bill of Materials

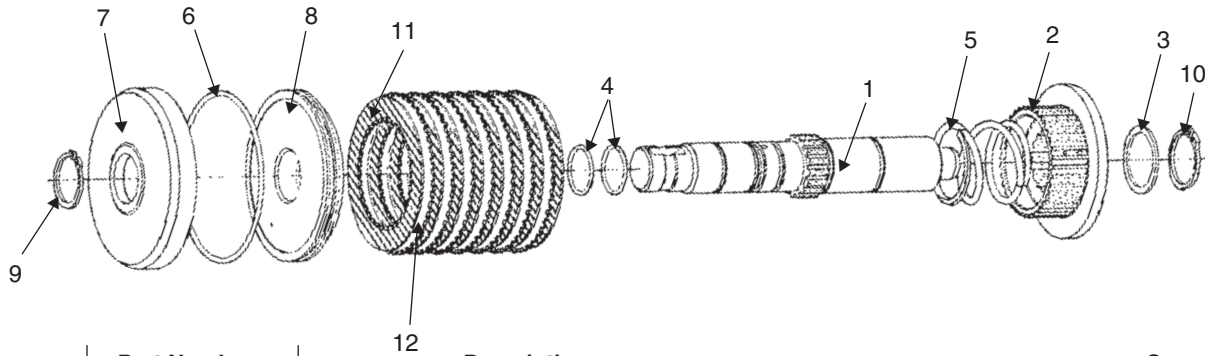

Item	Part Number	Description	Quantity
1	329006-1X 3-P-831	Assembly "XD" Output Drive Shaft "XD".....	1or
1	329006-2X 3-P-832	Assembly "XK" & "XP" Output Drive Shaft "XK" & "XP".....	1or
1	329006-3X 3-P-833	Assembly "PA", "RA", "RB" & "XR" Output Drive Shaft "PA", "RA", "RB" & "XR".....	1or
1	329006-4X 3-P-852	Assembly "XY" Output Drive Shaft "XY".....	1or
1	329006-5X 3-P-853	Assembly "XX" Output Drive Shaft "XX".....	1or
1	329006-6X 3-P-892	Assembly "AF" Output Drive Shaft "AF".....	1or
1	329006-8X 3-P-925	Assembly "XK" & "XP" Output Drive Shaft "XK" & "XP".....	1or
1	329006-9X 3-P-963	Assembly "XE" Output Drive Shaft "XE".....	1or
1	329006-10X 3-P-985	Assembly "BA" Output Drive Shaft "BA".....	1
1	329613X 3-P-999	Assembly "ZY" Output Drive Shaft "ZY".....	1
2	2-P-458	Inner Clutch Gear.....	1
3	14-P-49	Spacer.....	1
4	28-P-244	O-Ring.....	2
5	37-P-39	Clutch Spring.....	1
6	329179-1X 28-P-178	Piston & Backup Cyl. Sub. Assembly..... O-Ring.....	1 1
7	379323-1	Clutch Back-up Cylinder.....	1
8	380057-1	Clutch Piston.....	1
9	378576	Retaining Ring.....	1
10	379746	Retaining Ring.....	1
11	379485	Friction Disk.....	8
12	379595	Clutch Plate.....	7
"ZY" Output Only			
2	2-P-858	Inner Clutch Gear.....	1
3	14-P-49	Spacer.....	1
4	28-P-285	O-Ring.....	2
5	37-P-62	Clutch Spring.....	1
6	28-P-178	O-Ring.....	1
7	380051	Clutch Back-Up Cylinder.....	1
8	380110X	Clutch Piston.....	1
9	379555	Retaining Ring.....	1
10	379746	Retaining Ring.....	1
11	379485	Friction Disk.....	8
12	379595	Clutch Plate.....	7

Model Number Designation

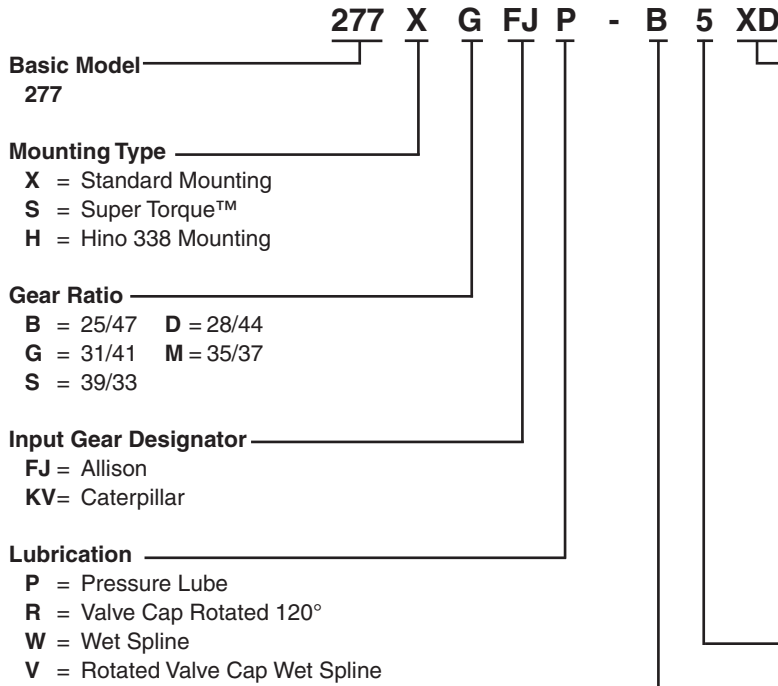

Output Type

- XV** = Shaft, 10-T Straight Spline w/3-1-3881 Flange
- XP** = S.A.E. "A" 2 Bolt 7/8"-13T
- XD** = 1.250" Rd. Std. Shaft
- XK** = S.A.E. "B" 2 or 4 Bolt
- XE** = S.A.E. "A" 2 Bolt 5/8"-9T
- XP** = S.A.E. "A" 2 Bolt
- XR** = CHELSEA Special
- AF** = S.A.E. "B" 2 or 4 Bolt
- BA** = 1-1/4" Rd. Shaft w/Self Adjusting Shaft Brake
- RA** = Rotatable S.A.E. "B" 2 Bolt
- RB** = Rotatable S.A.E. "B" 4 Bolt
- XY** = DIN 5462
- XX** = 1.250" Tapered
- RF** = Rotatable S.A.E. "B" 2 Bolt
- RG** = Rotatable S.A.E. "B" 4 Bolt
- PA** = S.A.E. "B" 2 Bolt w/Thru Holes, 7/8"-13T (P2 Pump)
- PF** = S.A.E. 2 Bolt w/Thru Holes, 1.0"-15T (P2 Pump)
- ZY** = DIN 5462 Wet Spline Only

Assembly Arrangement

5 Gear forward, shaft rear, bulge up right side, bulge down left side

Shifter Type

- B** = 12V Hydraulic Valve
- D** = 24V Hydraulic Valve
- G** = 12V Remote Hydraulic Valve w/o E.O.C.
- H** = 24V Remote Hydraulic Valve w/o E.O.C.
- K** = 12V Hydraulic Valve with E.O.C.
- L** = 24V Hydraulic Valve with E.O.C.
- M** = 12V without Installation Kit - 329024-12X
- N** = 24V without Installation Kit - 329024-24X
- S** = P.T.O./Dump Pump Combo Valve
- T** = P.T.O./Dump Pump Combo Valve less kickout

P.T.O. Housing Dimensions

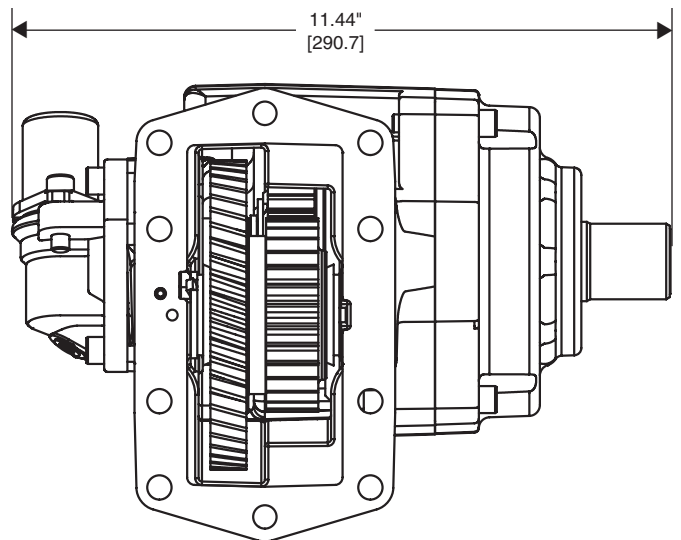
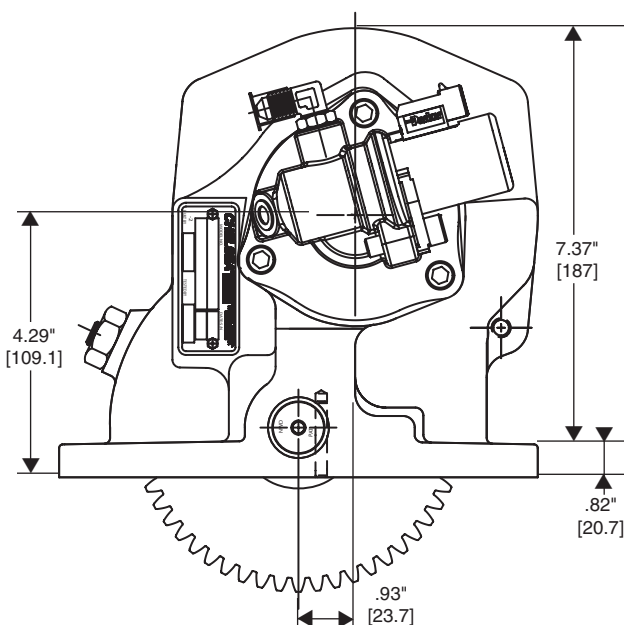

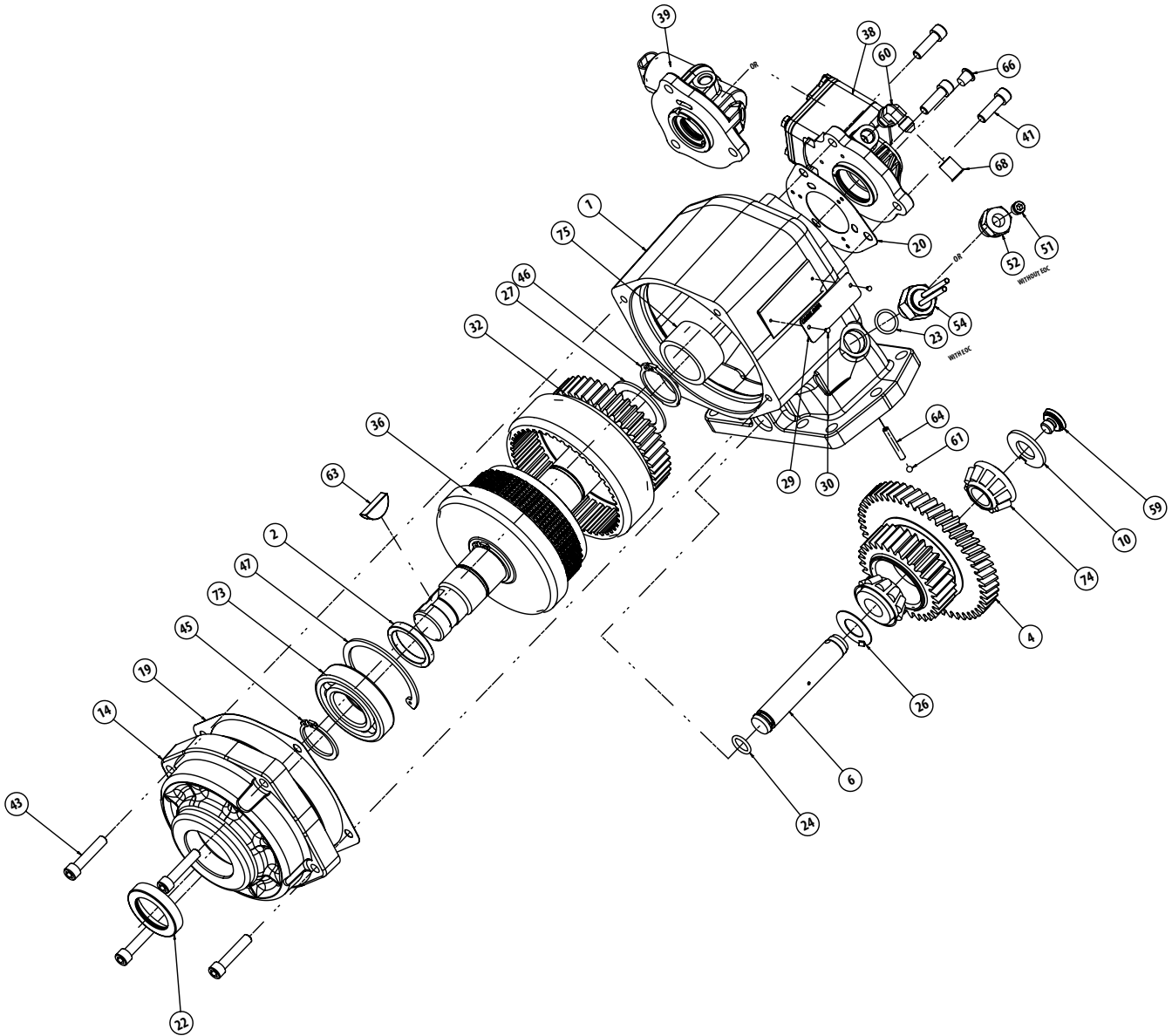

Item	Part Number	Description	Quantity
1	1-P-591	P.T.O. Housing	1
2	4-P-147	Spacer, Drive Shaft.....	1
	4-P-187	Spacer, ("ZY" Output)	1
4	See Page 10	Input Gear.....	1
6	9-P-91	Idler Shaft	1
10	14-P-79-1	Tabbed Washer (.112"-.114").....	A.R.
	14-P-79-2	Tabbed Washer (.116"-.118").....	
	14-P-79-3	Tabbed Washer (.120"-.122").....	
	14-P-79-4	Tabbed Washer (.124"-.126").....	
14	See Below	Bearing Cover (open)	1
	21-P-480	Bearing Cover ("XD" Output)	
	21-P-691	Bearing Cover ("BA" Output)	
	See Pages 16-21	Bearing Cover (All Other Outputs)	
19	22-P-101	Gasket Bearing Cap ("BA" Output).....	2 or
	22-P-101	Gasket Bearing Cap (All Other Outputs).....	1
20	22-P-112	Gasket, Valve Cap	1
22	See Below	Oil Seal.....	1
	28-P-225	Oil Seal (Output Side) ("XD" Output)	
	See Pages 16-21	Oil Seal	
23	28-P-171	O-Ring (All Other Outputs)	1
24	28-P-191	O-Ring	1
26	31-P-102	Thrust Washer	1
27	31-P-70	Thrust Washer	1
29	68-P-2	Name Plate.....	1
30	378422	Drive Screw	2
32	See Pages 10	Output Gear Sub Assembly.....	1
N.S.	560972	Bearing	1
N.S.	329403X	Seal Cap Assembly ("G" & "H" Shift Only).....	1
36	See Below	Drive Shaft & Clutch Ass'y.....	1
	329006-1X	Drive Shaft & Clutch Ass'y (3-P-831) ("XD" Output)	
	329006-10X	Drive Shaft & Clutch Ass'y (3-P-985) ("BA" Output)	
	See Page 11	Drive Shaft & Clutch Ass'y (All Other Outputs)	
38	See Page 13	Valve & Valve Cap Assembly (12V) "Old Style" ("FJ" Pitch Only)	1 or
	329352-12X	Valve & Valve Cap Assembly (24V) "Old Style" ("FJ" Pitch Only)	1 or
	329352-24X		
39	329442-12X	Valve & Valve Cap Assembly (12V) ("KV" Pitch Only)	1 or
	329442-24X	Valve & Valve Cap Assembly (24V) ("KV" Pitch Only)	1
	329463-12X	Valve & Valve Cap Assembly (12V) ("FJ" Pitch Only)	1 or
	329463-24X	Valve & Valve Cap Assembly (24V) ("FJ" Pitch Only)	1
41	378447-6	Soc. Hd. Capscrew .312"-18 x 1.00"	3
43	378447-16	Soc. Hd. Capscrew .312"-18 x 3.50" ("BA" Output)	4 or
	378447-8	Soc. Hd. Capscrew .312"-18 x 1.50" (All Other Outputs).....	4
45	378576	Retaining Ring ("BA" Output)	2 or
	378555	Retaining Ring ("ZY" Output)	1 or
	378576	Retaining Ring (All Other Outputs)	1
46	379746	Retaining Ring	1
47	378895	Retaining Ring	1
47	378895	Retaining Ring	1
51	379231	Pipe Plug .125"-27 NPTF (Without E.O.C. Only).....	1

A.R. — As Required N.S. — Not Shown

Continued on Next Page

Item	Part Number	Description	Quantity
52	379242	O-Ring Boss Plug (Without E.O.C. Only).....	
54	379243	Speed Sensor (With E.O.C. Only)	1
59	379672	NWD Plug.....	1
60	379486	Straight Thread Connector 90°	1
61	378108	Ball	1
63	500007-29	Woodruff Key ("XD" & "BA" Outputs)	1
64	500597-16	Spring Pin.....	1
66	500897-3	Shipping Plug	1
68	379564-2	Shipping Cap	1
73	550010	Ball Bearing.....	1
74	550439	Tapered Bearing Cone.....	2
75	560972	Needle Bearing.....	1
Loose Parts			
	328748X	Pump Mounting Kit (For "XR" Output Only)	1
	7170-107X	Mounting Kit.....	1
	379451	Guide Screw	2
	379453-8	Ferry Capscrew (M10-1.5" x 30mm)	1
	379453-10	Ferry Capscrew (M10-1.5" x 35mm)	7
	379486	90° Elbow Fitting w/ O-Ring.....	1
	328948-9X	Gasket & Installation Instructions	1
	7170-118X	Mounting Kit ("KV" Pitch Only)	
	379451	Guide Screw	2
	379453-8	Ferry Capscrew (M10-1.5" x 30mm)	1
	379453-10	Ferry Capscrew (M10-1.5 "x 35mm)	7
	379812	Straight Thread O-Ring Connector (7/16"-24)	1
	See Below	Installation Kit	1
	329024-12X	Installation Kit 12V (Less E.O.C.)	
	329024-24X	Installation Kit 24V (Less E.O.C.)	
	329076X	Installation Kit 12V & 24V (With E.O.C.)	
	329443-12X	Installation Kit 12V (For "KV" Pitch Only)	
	329443-24X	Installation Kit 24V (For "KV" Pitch Only)	
	329444X	Installation Kit 12V and 24V with E.O.C. (For "KV" Pitch Only)	
	329445-12X	Installation Kit 12V Remote Valve (For "KV" Pitch Only)	
	329445-24X	Installation Kit 24V Remote Valve (For "KV" Pitch Only)	
	328924-12X	Control Box 12V (With E.O.C.)	1 or
	328924-24X	Control Box 24V (With E.O.C.)	1
	328388-85X	Airshift Installation Kit "S" Shift Option.....	1
	328388-86X	Airshift Installation Kit "T" Shift Option	1
	329237-12X	Installation Kit Remote Valve option without E.O.C.....	1 or
	329237-24X	Installation Kit Remote Valve option without E.O.C.....	1
	329057-4X	Hose Assembly ("G" & "H" Shift Only)	1
	328075X	Hose Assembly ("G" & "H" Shift Only)	1
Service Kits			
	1-P-591X	P.T.O. Housing w/ Spring Pin	
	329071-19X	Gasket & Seal Kit	
	329071-33X	Gasket & Seal Kit (For "XY" Output Only)	
	329071-36X	Bearing Kit	
	329071-7X	Clutch Repair Kit	

A.R.—As Required N.S.—Not Shown

Continued on Next Page

Item	Part Number	Description	Quantity
	329175-12X	E.O.C. Field Conversion Kit 12V	
	329175-24X	E.O.C. Field Conversion Kit 24V	
	329160-59X	Conversion Kit "XD" to "BA" (Reference Page 15)	
	329043-21X	Service Kit "BA" Brake Section Only	
	329071-35X	Gasket & Seal Kit "BA"	
		Service Kits (Continued)	
	329354-12X	12X Remote Mount Valve Conversion Kit	
	329354-24X	24X Remote Mount Valve Conversion Kit	
	329447-12X	Kit 12V Remote Valve Conversion (For "KV" Pitch Only)	
	329447-24X	Kit 24V Remote Valve Conversion (For "KV" Pitch Only)	
	329448-12X	Kit 12V E.O.C. Field Conversion (For "KV" Pitch Only)	
	329448-24X	Kit 24V E.O.C. Field Conversion	

278 Gear Chart

Model Number	Input Gear Part Number Item No. 4	Number Teeth Lg/Sm	Output Gear Item No. 32		Gear & Bearing* Sub-assembly Items 32
			Part Number	Number Teeth	
278XBFJ	5-P-912	50/25	2-P-811	50	329005-11X
278XDFJ	5-P-913	50/28	2-P-688	47	329005-1X
278XGFJ	5-P-914	50/31	2-P-684	44	329005-2X
278XMFJ	5-P-915	50/35	2-P-814	40	329005-13X
278XSFJ	5-P-1173	50/39	2-P-815	36	329005-14X
278XTFJ	5-P-1409	50/42	2-P-756	33	329005-5X
SUPER TORQUE™					
278SBFJ	5-P-1350	50/25	2-P-812	50	329005-12X
278SDFJ	5-P-1293	50/28	2-P-800	47	329005-6X
278SGFJ	5-P-1225	50/31	2-P-790	44	329005-7X
278SMFJ	5-P-1351	50/35	2-P-816	40	329005-15X
278SSFJ	5-P-1278	50/39	2-P-817	36	329005-16X
278STFJ	5-P-1410	50/42	2-P-789	33	329005-10X
278XBKV	5-P-1361	45/25	2-P-811	50	329005-11X
278XDKV	5-P-1362	45/28	2-P-688	47	329005-1X
278XGKV	5-P-1363	45/31	2-P-684	44	329005-2X
278XMKV	5-P-1367	45/35	2-P-814	40	329005-13X
278XSKV	5-P-1369	45/39	2-P-815	36	329005-14X
SUPER TORQUE™					
278SBKV	5-P-1402	45/25	2-P-812	50	329005-12X
278SDKV	5-P-1413	45/28	2-P-800	47	329005-6X
278SGKV	5-P-1414	45/31	2-P-790	44	329005-7X
278SMKV	5-P-1415	45/35	2-P-816	40	329005-15X
278SSKV	5-P-1416	45/39	2-P-817	36	329005-16X

*Bearing Part Number 560972

278 Series Output Shafts & Clutch Assembly Bill of Materials

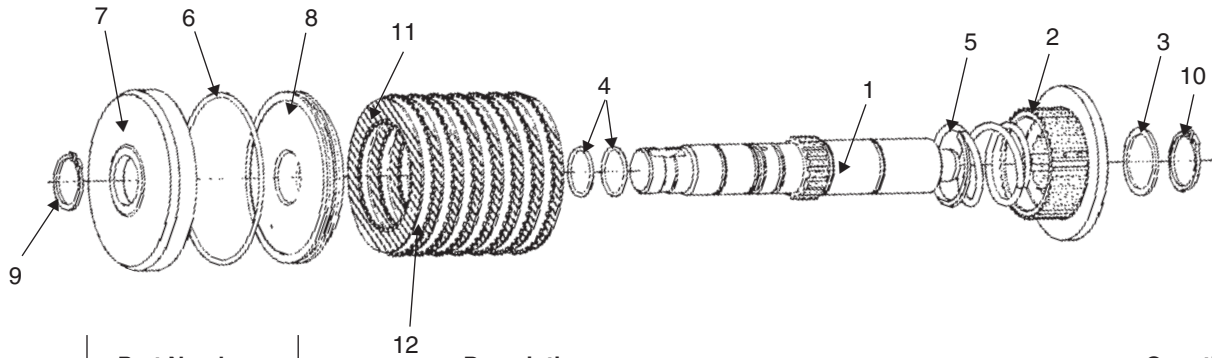

Item	Part Number	Description	Quantity
1	329006-1X 3-P-831	Assembly "XD" Output Drive Shaft "XD".....	1or
1	329006-2X 3-P-832	Assembly "XK" & "XP" Output Drive Shaft "XK" & "XP"	1or
1	329006-3X 3-P-833	Assembly "PA", "RA", "RB" & "XR" Output Drive Shaft "PA", "RA", "RB" & "XR"	1or
1	329006-4X 3-P-852	Assembly "XY" Output Drive Shaft "XY".....	1or
1	329006-5X 3-P-853	Assembly "XX" Output Drive Shaft "XX".....	1or
1	329006-6X 3-P-892	Assembly "AF" Output Drive Shaft "AF".....	1or
1	329006-8X 3-P-925	Assembly "XK" & "XP" Output Drive Shaft "XK" & "XP"	1or
1	329006-9X 3-P-963	Assembly "XE" Output Drive Shaft "XE".....	1or
1	329006-10X 3-P-985	Assembly "BA" Output Drive Shaft "BA".....	1
2	2-P-458	Inner Clutch Gear	1
3	14-P-49	Spacer	1
4	28-P-244	O-Ring	2
5	37-P-39	Clutch Spring.....	1
6	329179-1X 28-P-178	Piston & Backup Cyl. Sub. Assembly..... O-Ring	1 1
7	379323-1	Clutch Back-up Cylinder.....	1
8	379325-1	Clutch Piston	1
9	378576	Retaining Ring.....	1
10	379746	Retaining Ring.....	1
11	379485	Friction Disk.....	8
12	379595	Clutch Plate	7
"ZY" Output Only			
2	3-P-999	Drive Shaft.....	1
3	14-P-49	Spacer	1
4	28-P-285	O-Ring	2
5	37-P-62	Clutch Spring.....	1
6	28-P-178	O-Ring	1
7	380051	Clutch Back-Up Cylinder	1
8	380110X	Clutch Piston	1
9	379555	Retaining Ring	1
10	379746	Retaining Ring	1
11	379485	Friction Disk.....	8
12	379595	Clutch Plate	7

Model Number Designation

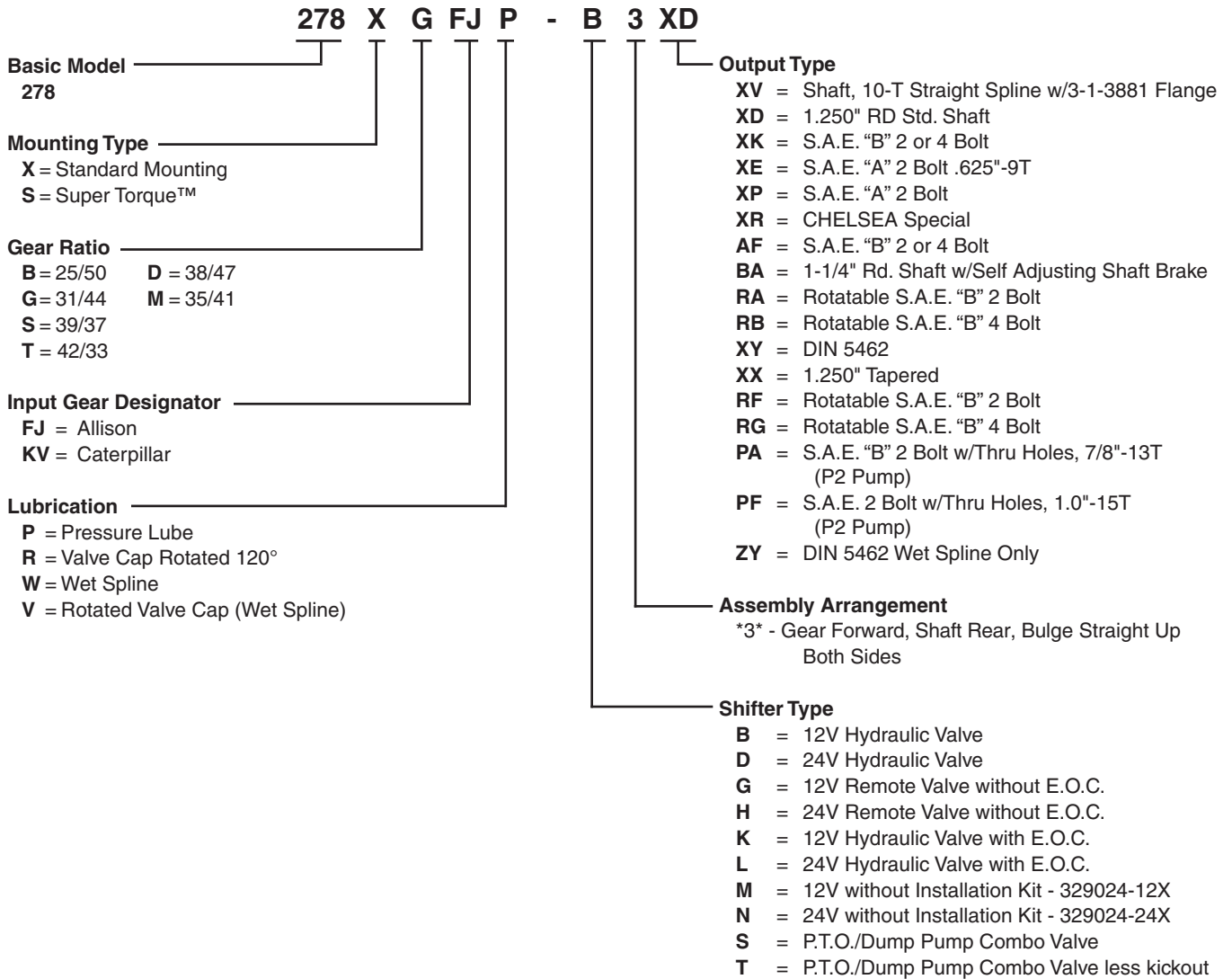

P.T.O. Housing Dimensions

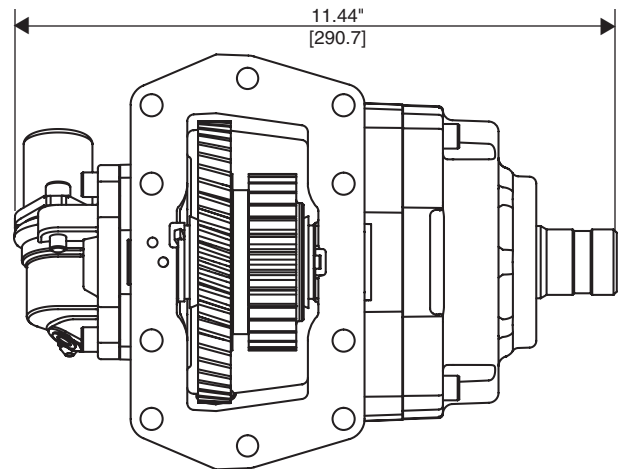
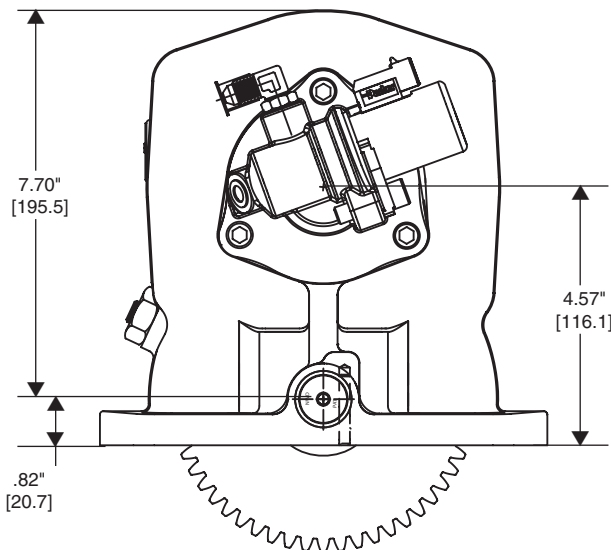

Valve & Cap Bill of Materials

329352

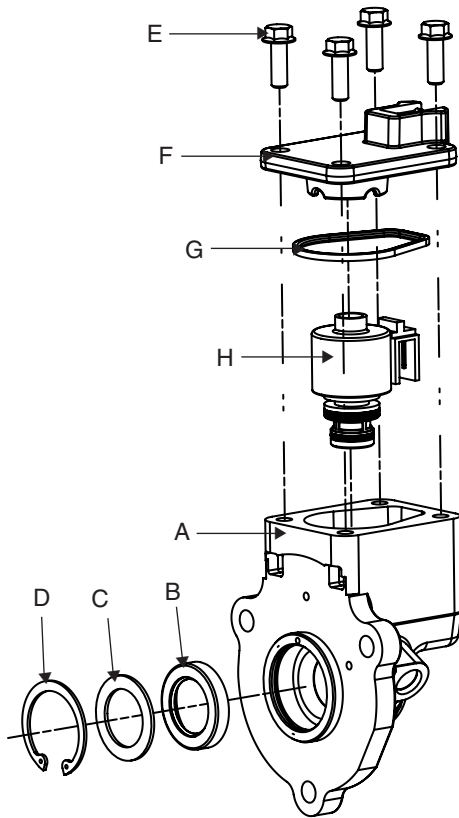

329442

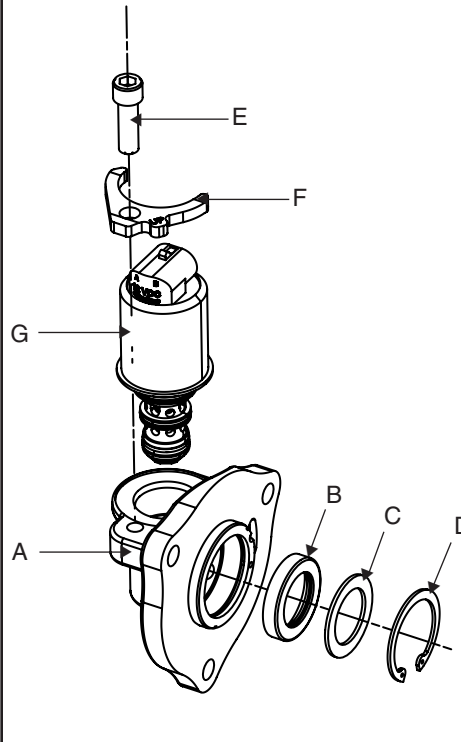

Item	Part Number	Description	Quantity
38	329352-12X	Valve & Cap Assembly (12V)	1 or
	329352-24X	Valve & Cap Assembly (24V)	1
A	34-P-278	Valve Cap	1
B	28-P-119	Oil Seal (Hi Pressure).....	1
C	378811	Washer	1
D	378849	Retaining Ring.....	1
E	379565	Hexhead Capscrew .250"-20 x .750".....	4
F	329144X	Valve Cap Cover (12V).....	1 or
	329144-1X	Valve Cap Cover (24V).....	1
G	28-P-193	Block Ring	1
H	379604-1	Hydraulic Valve (12V)	1 or
	379604-2	Hydraulic Valve (24V)	1
38	329442-12X	Valve & Cap Assembly (12V) ("KV" Pitch Only)	1 or
	329442-24X	Valve & Cap Assembly (24V) ("KV" Pitch Only)	1
	329463-12X	Valve & Cap Assembly (12V) ("FJ" Pitch Only)	1 or
	329463-24X	Valve & Cap Assembly (24V) ("FJ" Pitch Only)	1
A	34-P-143	Valve Cap	1
B	28-P-119	Oil Seal (Hi Pressure).....	1
C	378811	Washer	1
D	378849	Retaining Ring.....	1
E	378447-6	Sockethead Capscrew .312-18 x1.00"	1
F	379995	Clamp ("KV")	1 or
	380012	Clamp ("FJ")	1
G	379993-12	Hydraulic Valve (12V) ("KV") (White Connector)	1 or
	379993-24	Hydraulic Valve (24V) ("KV") (Black Connector).....	1
	380123-12	Hydraulic Valve (12V) ("FJ") (White Connector).....	1 or
	380123-24	Hydraulic Valve (24V) ("FJ") (Black Connector).....	1

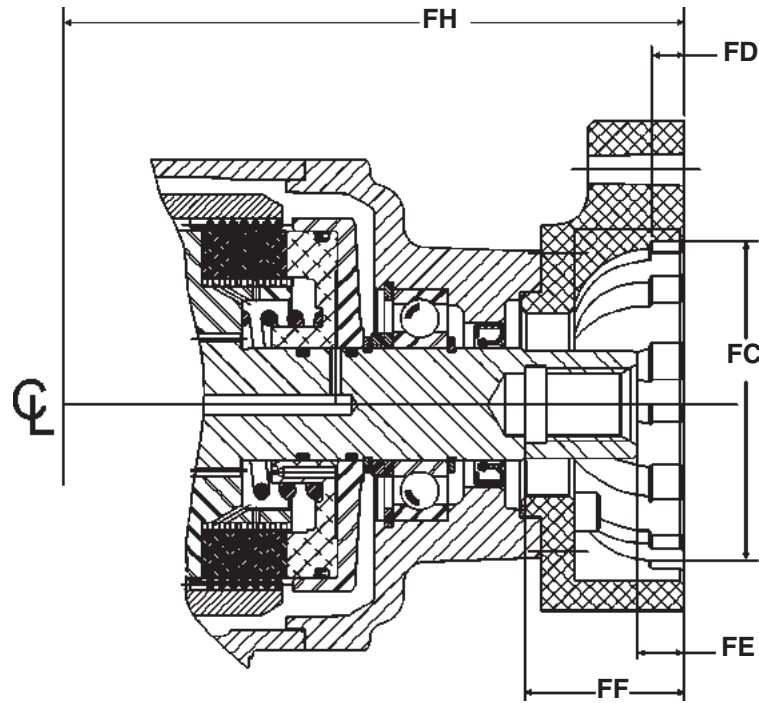

277/278 Series

Pump Flange Suffix	Bolt Circle Diameter	Bolt Holes		FC Female Pilot of Flange	FD Pilot Depth Hole	FE Face to End of P.T.O.	FF Face Thru	FH Face to Center	Output Shaft	
		Tapered Hole Diameter	No. Equally Spaced						Hole Diameter	Keyway Width
AF	5.000"	.500"-13	4	4.003"	0.406"	2.060"	7.304"		1.00"-15 Spline	
	5.750"	.500"-13	2							
BA	-	-	-	-	-	-	-	9.045"	1.25" Round	.3125"
XK	5.000"	.500"-13	4	4.003"	0.406"	0.562"	1.940"	6.410"	.875"-13 Spline	-
	5.750"	.500"-13	2							
XP	4.188"	.375"-16+	2	3.253"	0.344"	0.562"	1.940"	6.410"	.875"-13 Spline	-
XR	3.710"	.312"-18+	4	2.752"	0.281"	N/A	N/A	5.860"	.875"-13 Spline	
XY	3.150"	M12 x 1.75"	4	3.152"	0.394"	0.550"	2.250"	9.030"	1.420"-8 Spline	
XX*	N/A	N/A	N/A	N/A	N/A	N/A	N/A	N/A	1.250" S.A.E. Taper	.3125"
RA ♦	5.750"	4 x .500"-13	4	4.003"	0.406"	0.574"	2.056"	7.605"	0.875"-13 Spline	
RF ♦	5.750"	4 x .500"-13	2●	4.003"	0.406"	0.574"	2.056"	7.605"	1.000"-15 Spline	
RG ♦	3.552"	4 x .500"-13	4	4.003"	0.406"	0.574"	2.060"	7.610"	1.000"-15 Spline	
RB ♦	3.552"	4 x .500"-13	4	4.003"	0.406"	0.574"	2.060"	7.610"	0.875"-13 Spline	
PF ♦	5.750"	4 x .500"-13	4	4.003"	0.406"	0.574"	2.056"	7.605"	1.000"-15 Spline	
PA ♦	5.750"	4 x .500"-13	4	4.003"	0.406"	0.574"	2.056"	7.605"	0.875"-13 Spline	
ZY	3.150"	M12 x 1.75"	4	3.152"	-	0.550"	2.250"	6.260"	1.420"-8 Spline	

- * Requires customer supplied companion flange, Spicer part number 3-1-604.
- ♦ Rotatable Flange Rotates in 30° Increments
- Flange has two sets of holes offset 14°
- ‡ Hole tapped .750" deep

CAUTION: All pump mounting dimensions shown are compiled to conform to S.A.E. standards; however it shall be the responsibility of the user to determine the correct fit at the time the pump is mounted to the P.T.O. Therefore carefully check the shaft and key or spline engagement.

NOTE: Apply a generous amount of spline lubricant part number 379688 to the inside of shaft. Must cover tooth space.

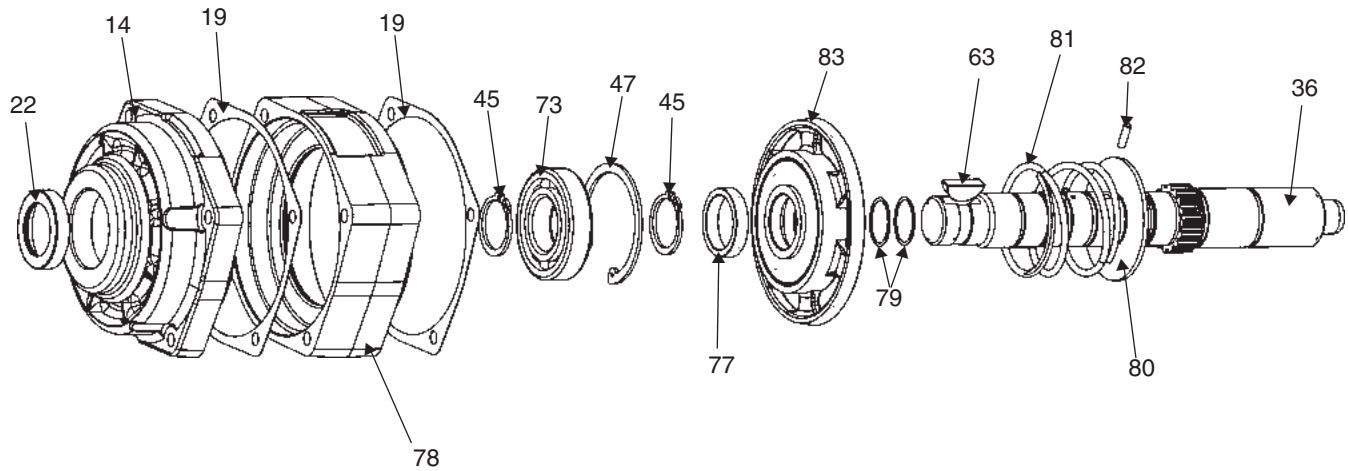

Item	Part Number	Description	Quantity
	329006-10X	Drive Shaft & Clutch Ass'y ("BA" Output) 277/278 Series	1
14	21-P-691	Bearing Cover "BA" Only ("BA" Output)	
19	22-P-101	Gasket Bearing Cap ("BA" Output)	2
22	28-P-225	Oil Seal (Output Side)	1
36	3-P-985	Output Shaft	1
45	378576	Retaining Ring ("BA" Output)	3
47	378895	Retaining Ring	1
63	500007-29	Woodruff Key	1
73	550010	Ball Bearing	1
77	4-P-186	Spacer, Drive Shaft	1
78	23-P-68	Spacer ("BA" Output Parts)	1
79	28-P-244	O-Ring	2
80	31-P-113	Thrust Washer ("BA" Output Parts)	1
81	37-P-60	Spring ("BA" Output Parts)	1
82	379977	Pin .187" x .625" ("BA" Output Parts)	1
83	329410X	Brake Assembly ("BA" Output Parts)	1

Pump Flange Conv. Kits Bills of Materials

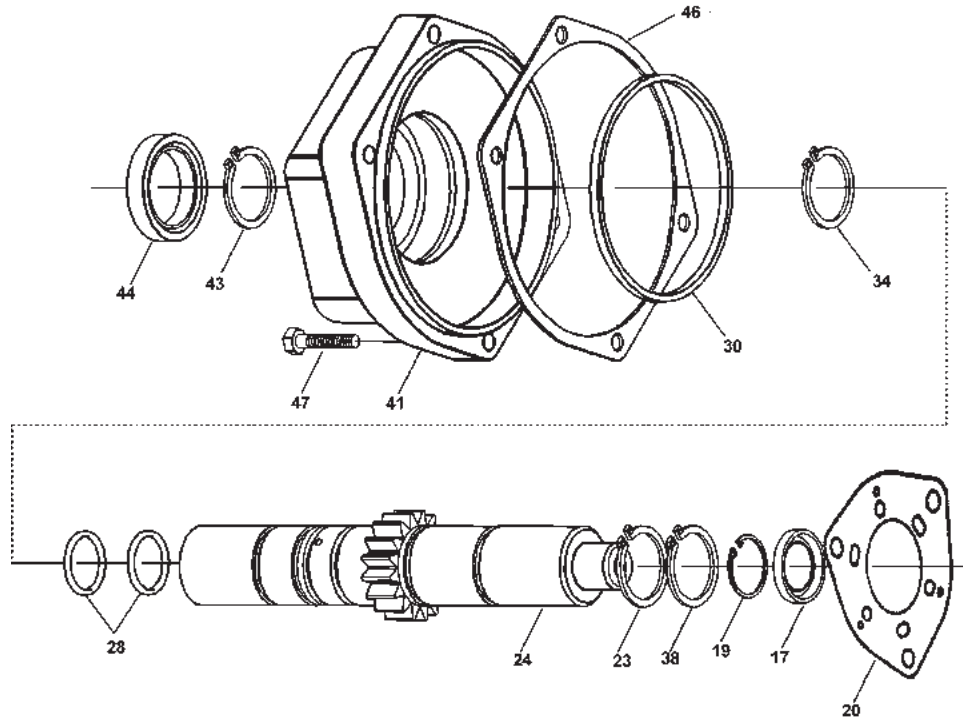

Conversion Kit Number	Ass'y 277/278	Flange Type	Shaft Type
329160-21X	XD-AK	5/3	S.A.E. "B" 2 or 4 Bolt Flange
329160-22X	XD-XR	5/3	For Parker P16 "S" Flange Pumps
329160-23X	XD-XP	5/3	S.A.E. "A" 2 Bolt (4.188 BC) w/ S.A.E. "B" 4 Bolt (5.0" BC)
329160-24X	XD-XY	5/3	S.A.E. "B" 2 or 4 Bolt Flange
329160-25X	XD-AF	5/3	S.A.E. "B" 2 or 4 Bolt Flange
329160-35X	XR-RA	5/3	S.A.E. "B" 2 Bolt Rotatable Flange
329160-36X	XR-RB	5/3	S.A.E. "B" 4 Bolt Rotatable Flange
329160-37X	XD-RA	5/3	S.A.E. "B" 2 Bolt Rotatable Flange
329160-38X	XD-RB	5/3	S.A.E. "B" 4 Bolt Rotatable Flange
329160-39X	XD-RF	5/3	S.A.E. "B" 2 Bolt Rotatable Flange
329160-45X	XD-RG	5/3	S.A.E. "B" 4 Bolt Rotatable Flange
329160-56X	XD-PF	5/3	S.A.E. "B" 2 Bolt Rotatable Flange w/Thru Holes
329160-57X	XD-PA	5/3	S.A.E. "B" 2 Bolt Rotatable Flange w/Thru Holes
329160-58X	XD-XE	5/3	S.A.E. "A" 2 Bolt Flange
329160-59X	XD-BA	5/3	Shaft Brake
			S.A.E. "B" .875" 13 - Tooth
			S.A.E. "B" .875" 13 - Tooth
			S.A.E. "B" .875" 13 - Tooth
			S.A.E. "B" .875" 13 - Tooth
			S.A.E. "BB" 1.0" 15 - Tooth
			S.A.E. "B" .875" 13 - Tooth
			S.A.E. "B" .875" 13 - Tooth
			S.A.E. "B" .875" 13 - Tooth
			S.A.E. "BB" 1.0" 15 - Tooth
			S.A.E. "BB" 1.0" 15 - Tooth
			S.A.E. "BB" 1.0" 15 - Tooth
			S.A.E. "B" .875" 13 - Tooth
			S.A.E. "B" .875" 13 - Tooth
			S.A.E. "A" .625" 9 - Tooth
			1-1/4" Rd Shaft w/Shaft Brake

Item	Part Number	Description	Quantity
	329160-21X	Conversion Kit (XD-XK)	
17	28-P-119	Oil Seal, High Pressure	1
19	378849	Retaining Ring.....	1
20	22-P-112	Gasket, Valve Cap	1
23	379746	Retaining Ring.....	1
24	3-P-832	Output Shaft	1
28	28-P-244	O-Ring	2
30	28-P-121	Block -v- Ring	1
34	378576	Retaining Ring.....	1
38	379746	Retaining Ring.....	1
41	21-P-482	Bearing Cap	1
43	378576	Retaining Ring.....	1
44	28-P-225	Oil Seal.....	1
46	22-P-101	Gasket, Bearing Cap	1
47	378447-8	Socket Head Capscrew (.3125"-18 x 1.500")	4
N.S.	379688	Grease Pack.....	1

N.S.—Not Shown

Pump Flange Conv. Kits Bills of Materials

Item	Part Number	Description	Quantity
	329160-22X	Conversion Kit (XD-XR)	
17	28-P-119	Oil Seal, High Pressure	1
19	378849	Retaining Ring.....	1
20	22-P-112	Gasket, Valve Cap	1
23	379746	Retaining Ring.....	1
24	3-P-833	Output Shaft	1
28	28-P-244	O-Ring	2
30	28-P-121	Block -v- Ring	1
34	378576	Retaining Ring.....	1
38	379746	Retaining Ring.....	1
41	21-P-484	Bearing Cap	1
43	378576	Retaining Ring.....	1
44	28-P-225	Oil Seal.....	1
46	22-P-101	Gasket, Bearing Cap	1
47	378447-8	Socket Head Capscrew (.3125"-18 x 1.500")	4
N.S.	379688	Grease Pack	1
N.S.	328748X	Pump Mounting Kit.....	1
N.S.	378430-11	Hex Capscrew (.3125"-18 x 1.125")	4
N.S.	378919	Washer	4
N.S.	45-P-11	Steel Guide.....	4
	329160-23X	Conversion Kit (XD-XP)	
17	28-P-119	Oil Seal, High Pressure	1
19	378849	Retaining Ring.....	1
20	22-P-112	Gasket, Valve Cap	1
23	379746	Retaining Ring.....	1
24	3-P-832	Output Shaft	1
28	28-P-244	O-Ring	2
30	28-P-121	Block -v- Ring	1
34	378576	Retaining Ring.....	1
38	379746	Retaining Ring.....	1
41	21-P-568	Bearing Cap	1
43	378576	Retaining Ring.....	1
44	28-P-225	Oil Seal.....	1
46	22-P-101	Gasket, Bearing Cap	1
47	378447-8	Socket Head Capscrew (.3125"-18 x 1.500")	4
N.S.	379688	Grease Pack	1
	329160-24X	Conversion Kit (XD-XY)	
17	28-P-119	Oil Seal, High Pressure	1
19	378849	Retaining Ring.....	1
20	22-P-112	Gasket, Valve Cap	1
23	379746	Retaining Ring.....	1
24	3-P-852	Output Shaft	1
28	28-P-244	O-Ring	2
30	28-P-121	Block -v- Ring	1
34	378576	Retaining Ring.....	1
38	379746	Retaining Ring.....	1
41	21-P-524	Bearing Cap	1
43	378576	Retaining Ring.....	1
44	28-P-230	Oil Seal.....	1
46	22-P-101	Gasket, Bearing Cap	1
47	378447-8	Socket Head Capscrew (.3125"-18 x 1.500")	4
N.S.	379688	Grease Pack	1
N.S.	378898	Flat Head Socket Screw (.438"-14 x 1.000")	1
N.S.	379335	Coupling, Splined	1

N.S.—Not Shown

Pump Flange Conv. Kits Bills of Materials

Item	Part Number	Description	Quantity
	329160-25X	Conversion Kit (XD-AF)	
17	28-P-119	Oil Seal, High Pressure	1
19	378849	Retaining Ring	1
20	22-P-112	Gasket, Valve Cap	1
23	379746	Retaining Ring	1
24	3-P-892	Output Shaft	1
28	28-P-244	O-Ring	2
30	28-P-121	Block -v- Ring	1
34	378576	Retaining Ring	1
38	379746	Retaining Ring	1
41	21-P-576	Bearing Cap	1
43	378576	Retaining Ring	1
44	28-P-225	Oil Seal	1
46	22-P-101	Gasket, Bearing Cap	1
47	378447-8	Socket Head Capscrew (.3125"-18 x 1.500")	4
N.S.	379688	Grease Pack	1
	329160-35X	Conversion Kit (XR-RA)	
N.S.	21-P-576	Rotatable Pump Flange (Mounts to 21-P-484)	1
N.S.	378447-6	Socket Head Capscrew (.3125"-18 x 1.000")	4
	329160-36X	Conversion Kit (XR-RB)	
N.S.	21-P-572	Rotatable Pump Flange (Mounts to 21-P-484)	1
N.S.	378447-6	Socket Head Capscrew (.3125"-18 x 1.000")	4
	329160-37X	Conversion Kit (XD-RA)	
17	28-P-119	Oil Seal, High Pressure	1
19	378849	Retaining Ring	1
20	22-P-112	Gasket, Valve Cap	1
23	379746	Retaining Ring	1
24	3-P-833	Output Shaft	1
28	28-P-244	O-Ring	2
30	28-P-121	Block -v- Ring	1
34	378576	Retaining Ring	1
38	379746	Retaining Ring	1
41	21-P-484	Bearing Cap	1
N.S.	21-P-628	Pump Flange (Rotatable Flange)	1
43	378576	Retaining Ring	1
44	28-P-225	Oil Seal	1
46	22-P-101	Gasket, Bearing Cap	1
47	378447-8	Socket Head Capscrew (.3125"-18 x 1.500")	4
	378447-6	Socket Head Capscrew (.3125"-18 x 1.000") (Rotatable Flange)	4
N.S.	379688	Grease Pack	1
N.S.	328748X	Pump Mounting Kit	1
N.S.	378430-11	Hex Capscrew (.3125"-18 x 1.125")	4
N.S.	378919	Washer	4
N.S.	45-P-11	Steel Guide	4

N.S.—Not Shown

Pump Flange Conv. Kits Bills of Materials

Item	Part Number	Description	Quantity
	329160-38X	Conversion Kit (XD-RB)	
17	28-P-119	Oil Seal, High Pressure	1
19	378849	Retaining Ring	1
20	22-P-112	Gasket, Valve Cap	1
23	379746	Retaining Ring	1
24	3-P-833	Output Shaft	1
28	28-P-244	O-Ring	2
30	28-P-121	Block -v- Ring	1
34	378576	Retaining Ring	1
38	379746	Retaining Ring	1
41	21-P-484	Bearing Cap	1
N.S.	21-P-572	Pump Flange (Rotatable Flange)	1
43	378576	Retaining Ring	1
44	28-P-225	Oil Seal	1
46	22-P-101	Gasket, Bearing Cap	1
47	378447-8	Socket Head Capscrew (.3125"-18 x 1.500")	4
	378447-6	Socket Head Capscrew (.3125"-18 x 1.000") (Rotatable Flange)	4
N.S.	379688	Grease Pack	1
N.S.	328748X	Pump Mounting Kit	1
N.S.	378430-11	Hex Capscrew (.3125"-18 x 1.125")	4
N.S.	378919	Washer	4
N.S.	45-P-11	Steel Guide.....	4
	329160-39X	Conversion Kit (XD-RF)	
17	28-P-119	Oil Seal, High Pressure	1
19	378849	Retaining Ring	1
20	22-P-112	Gasket, Valve Cap	1
23	379746	Retaining Ring	1
24	3-P-925	Output Shaft	1
28	28-P-244	O-Ring	2
30	28-P-121	Block -v- Ring	1
34	378576	Retaining Ring	1
38	379746	Retaining Ring	1
41	21-P-484	Bearing Cap	1
N.S.	21-P-628	Pump Flange (Rotatable Flange)	1
43	378576	Retaining Ring	1
44	28-P-225	Oil Seal	1
46	22-P-101	Gasket, Bearing Cap	1
47	378447-8	Socket Head Capscrew (.3125"-18 x 1.500")	4
	378447-6	Socket Head Capscrew (.3125"-18 x 1.000") (Rotatable Flange)	4
N.S.	379688	Grease Pack	1
N.S.	328748X	Pump Mounting Kit	1
N.S.	378430-11	Hex Capscrew (.3125"-18 x 1.125")	4
N.S.	378919	Washer	4
N.S.	45-P-11	Steel Guide.....	4

N.S.—Not Shown

Pump Flange Conv. Kits Bills of Materials

Item	Part Number	Description	Quantity
	329160-45X	Conversion Kit (XD-RG)	
17	28-P-119	Oil Seal, High Pressure	1
19	378849	Retaining Ring.....	1
20	22-P-112	Gasket, Valve Cap	1
23	379746	Retaining Ring.....	1
24	3-P-925	Output Shaft	1
28	28-P-244	O-Ring	2
30	28-P-121	Block -v- Ring	1
34	378576	Retaining Ring.....	1
38	379746	Retaining Ring.....	1
41	21-P-484	Bearing Cap	1
N.S.	21-P-572	Pump Flange (Rotatable Flange)	1
43	378576	Retaining Ring.....	1
44	28-P-225	Oil Seal.....	1
46	22-P-101	Gasket, Bearing Cap	1
47	378447-8	Socket Head Capscrew (.3125"-18 x 1.500")	4
	378447-6	Socket Head Capscrew (.3125"-18 x 1.000") (Rotatable Flange)	4
N.S.	379688	Grease Pack	1
N.S.	328748X	Pump Mounting Kit.....	1
N.S.	378430-11	Hex Capscrew (.3125"-18 x 1.125")	4
N.S.	378919	Washer	4
N.S.	45-P-11	Steel Guide.....	4
	329160-56X	Conversion Kit (XD-PF)	
17	28-P-119	Oil Seal, High Pressure	1
19	378849	Retaining Ring.....	1
20	22-P-112	Gasket, Valve Cap	1
23	379746	Retaining Ring.....	1
24	3-P-925	Output Shaft	1
28	28-P-244	O-Ring	2
30	28-P-121	Block -v- Ring	1
34	378576	Retaining Ring.....	1
38	379746	Retaining Ring.....	1
41	21-P-484	Bearing Cap	1
N.S.	21-P-661	Pump Flange (Rotatable Flange)	1
43	378576	Retaining Ring.....	1
44	28-P-225	Oil Seal.....	1
46	22-P-101	Gasket, Bearing Cap	1
47	378447-8	Socket Head Capscrew (.3125"-18 x 1.500")	4
	378447-6	Socket Head Capscrew (.3125"-18 x 1.000") (Rotatable Flange)	4
N.S.	379688	Grease Pack	1
N.S.	328748X	Pump Mounting Kit.....	1
N.S.	378430-11	Hex Capscrew (.3125"-18 x 1.125")	4
N.S.	378919	Washer	4
N.S.	45-P-11	Steel Guide.....	4

N.S.—Not Shown

Pump Flange Conv. Kits Bills of Materials

Item	Part Number	Description	Quantity
	329160-57X	Conversion Kit (XD-PA)	
17	28-P-119	Oil Seal, High Pressure	1
19	378849	Retaining Ring	1
20	22-P-112	Gasket, Valve Cap	1
23	379746	Retaining Ring	1
24	3-P-833	Output Shaft	1
28	28-P-244	O-Ring	2
30	28-P-121	Block -v- Ring	1
34	378576	Retaining Ring	1
38	379746	Retaining Ring	1
41	21-P-484	Bearing Cap	1
N.S.	21-P-661	Pump Flange (Rotatable Flange)	1
43	378576	Retaining Ring	1
44	28-P-225	Oil Seal	1
46	22-P-101	Gasket, Bearing Cap	1
47	378447-8	Socket Head Capscrew (.3125"-18 x 1.500")	4
	378447-6	Socket Head Capscrew (.3125"-18 x 1.000") (Rotatable Flange)	4
N.S.	379688	Grease Pack	1
N.S.	328748X	Pump Mounting Kit	1
N.S.	378430-11	Hex Capscrew (.3125"-18 x 1.125")	4
N.S.	378919	Washer	4
N.S.	45-P-11	Steel Guide	4
	329160-58X	Conversion Kit (XD-XE)	
20	22-P-112	Gasket, Valve Cap	1
24	3-P-963	Output Shaft	1
28	28-P-244	O-Ring	2
34	378576	Retaining Ring	2
38	379746	Retaining Ring	2
41	21-P-568	Bearing Cap	1
44	28-P-225	Oil Seal	1
46	22-P-101	Gasket, Bearing Cap	1
47	378447-8	Socket Head Cap Screw (.3125"-18 x 1.500")	4
N.S.	379688	Grease Pack	1
	329160-59X	Conversion Kit (XD-BA) Reference Page 15	
14	21-P-691	Bearing Cover "BA" only ("BA" Output)	1
19	22-P-101	Gasket, Bearing Cap	2
22	28-P-225	Oil Seal	1
36	3-P-985	Output Shaft	1
45	378576	Retaining Ring	1
47	378895	Retaining Ring	1
63	500007-29	Woodruff Key ("BA" Output Only)	1
73	550010	Ball Bearing	1
78	23-P-68	Spacer ("BA" Output Parts)	1
77	4-P-186	Shaft Spacer	1
79	28-P-244	O-Ring	4
83	329410X	Brake Assembly ("BA" Output Parts)	1
N.S.	378447-16	Socket Head Capscrew .312"-18 x 3.50"	4

N.S.—Not Shown

Installation "ZY" Wet Spline 277 & 278 Series (SK-454 Rev A)

379964 Adapter w/Restriction

500841-1 90° Elbow

379659 Tee Connect
 to Transmission
 Pressure Port
 See Chart for
 Hose Lengths

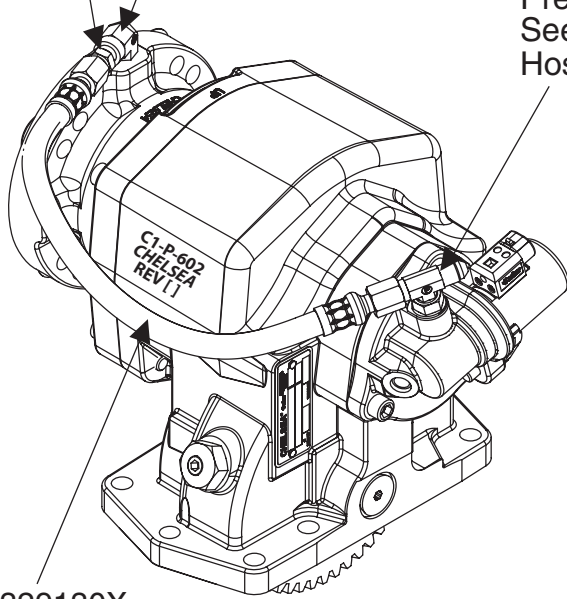

Install 22-P-84
 Gasket Between
 P.T.O. and Pump

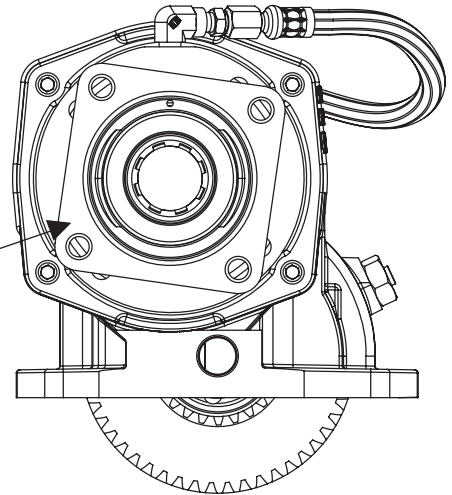

329130X
 Lube Hose

Fitting to Transmission Pressure Tap

379486
 (Part of 7170-107X)

Hose - See Chart
 Order Separately

90° Fitting

Fitting to P.T.O.

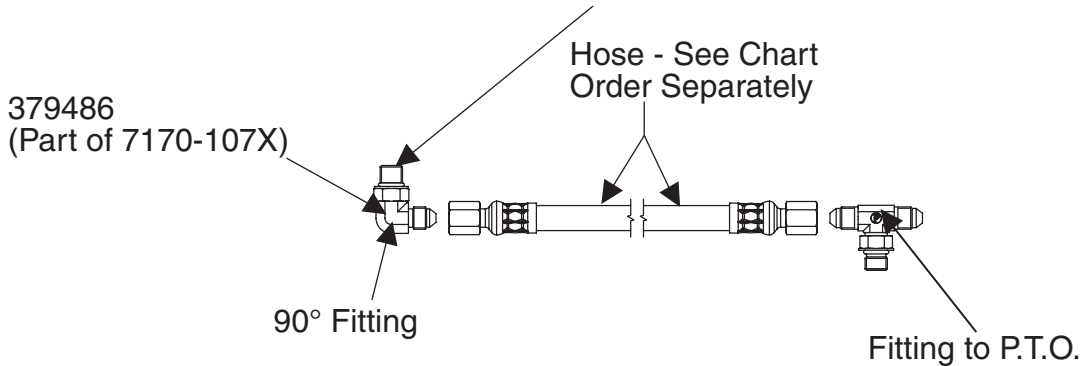

Pressure Hose Chart (Transmission to P.T.O.)		
Trans	Location	Hose
MD	Left	329130-5X
MD	Right	329075-1X
HD	Left	329075-4X
HD	Right	329075-2X

Shift Installation Kit 277, 278 & 859 Series without Electronic Overspeed Control (SK-347 Rev E)

329024-12X 12V Installation Kit
 329024-24X 24V Installation Kit

NOTE: * Pre - 2005-Connect to J1-6 (TCM) or Wire #106
 2005 and Later - Connect to 43 (TCM) or Wire #143.

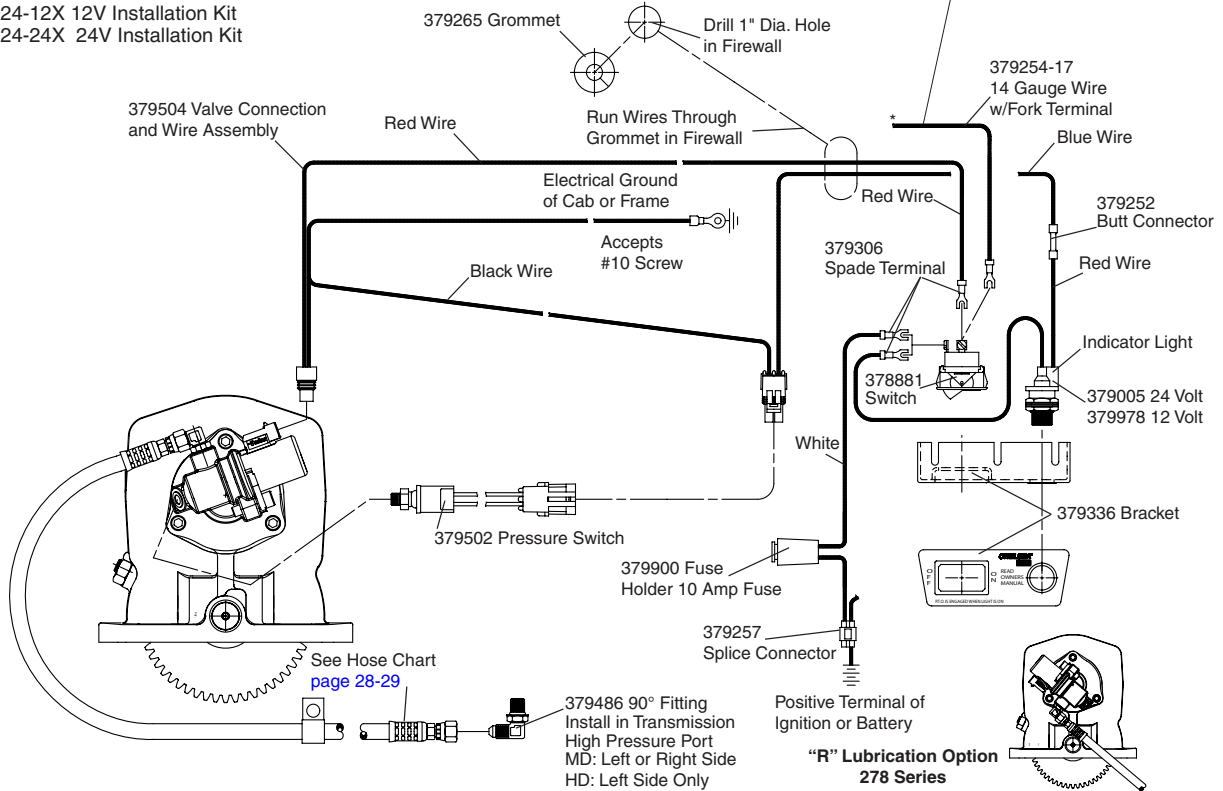

Shift Installation Kit 277, 278 & 859 Series with Electronic Overspeed Control (SK-348 Rev C)

329076X Installation Kit

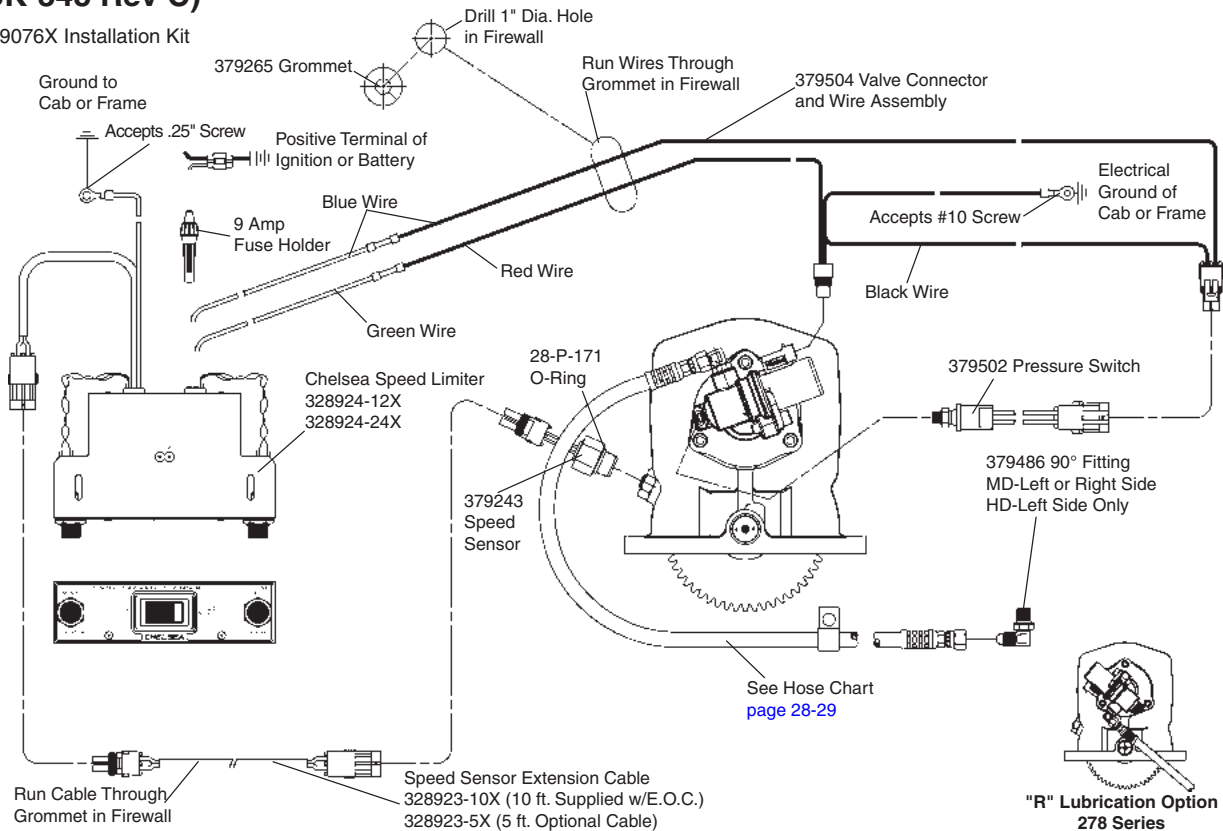

Shift Installation Kit 277/278 Series with Remote Mount Solenoid (SK-432 Rev C) Allison

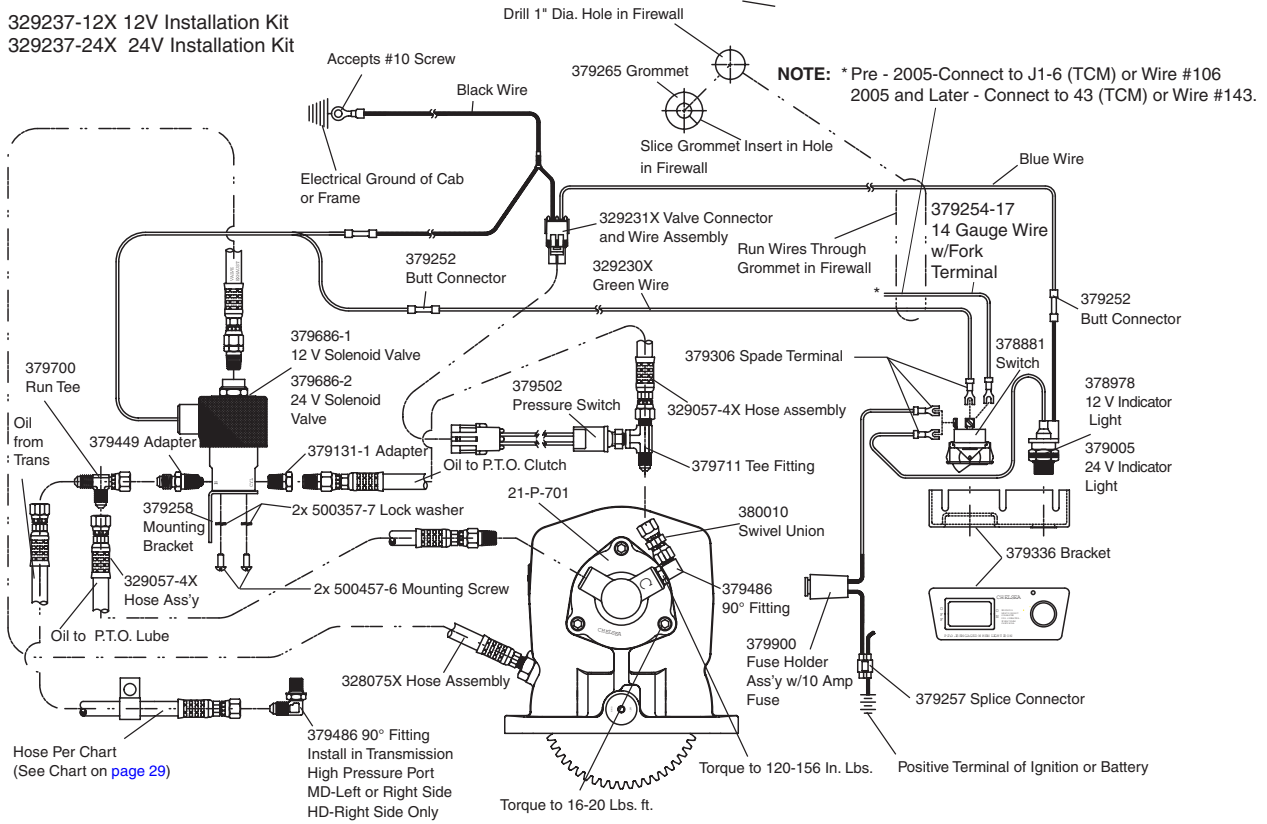

NOTE: This option is not available with nor can it be used on E.O.C. applications.

Shift Installation Kit 277 Series with Remote Mount Solenoid for Hino Model 338 (SK-410 Rev B)

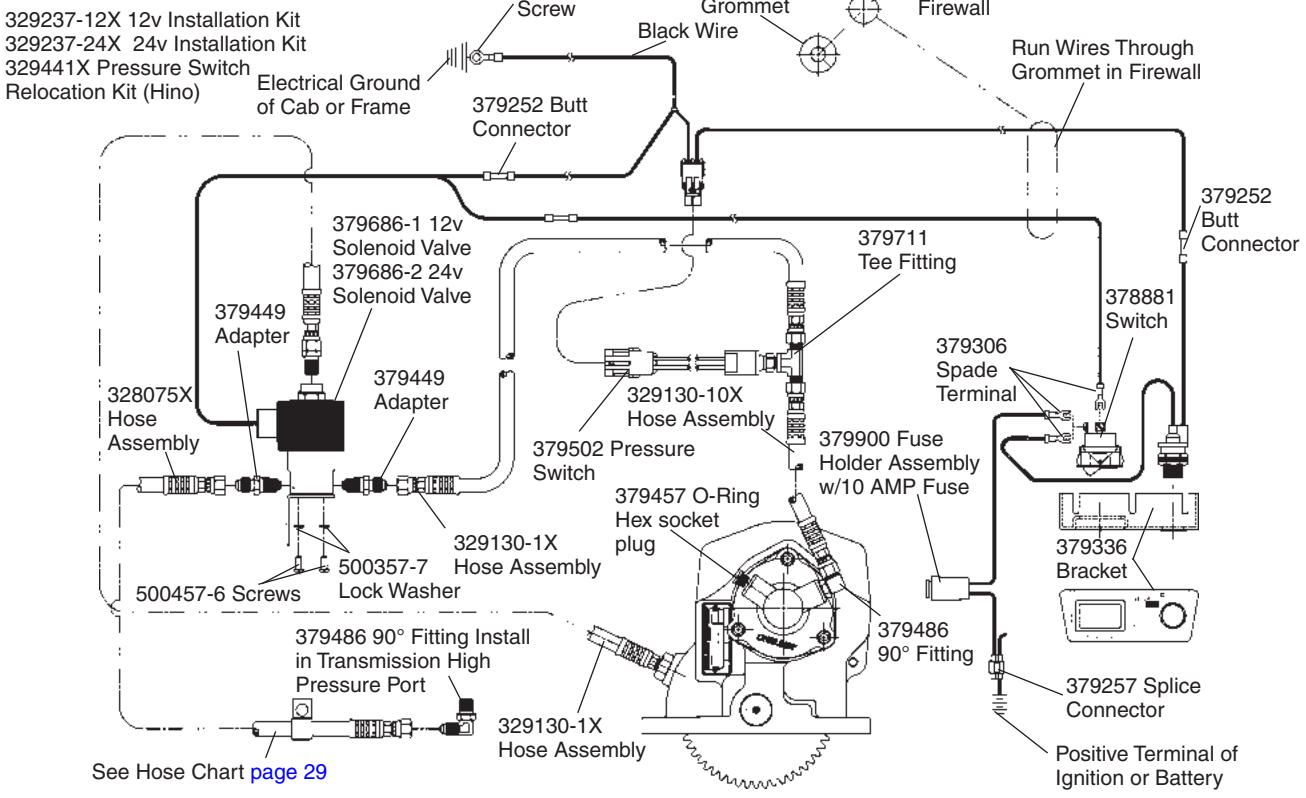

Shift Installation Kit 277/278 Series Without E.O.C. (SK-411 Rev A) Caterpillar

329443-12X - For 12v Installation Kit
 329443-24X - For 24v Installation Kit

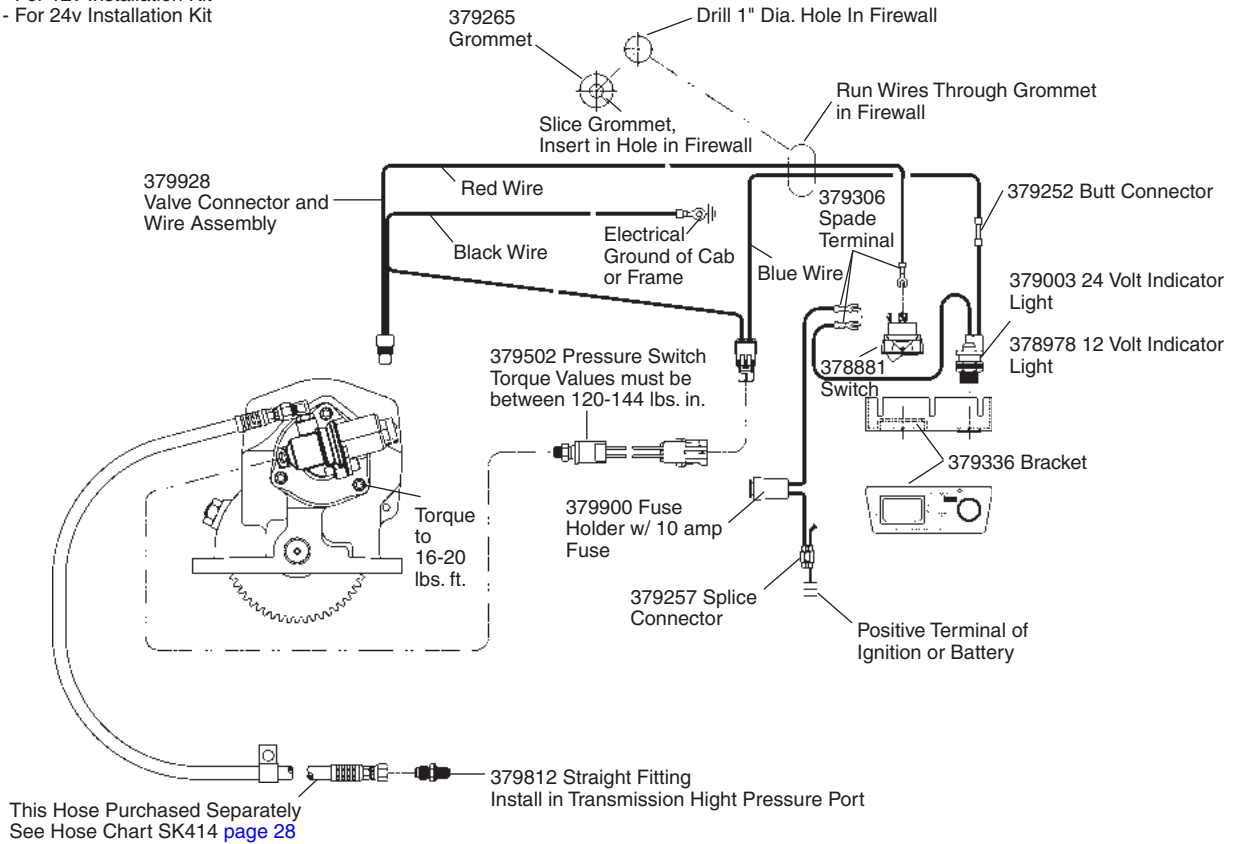

E.O.C. Installation Sketch for 277/278 Series (SK-473) Caterpillar

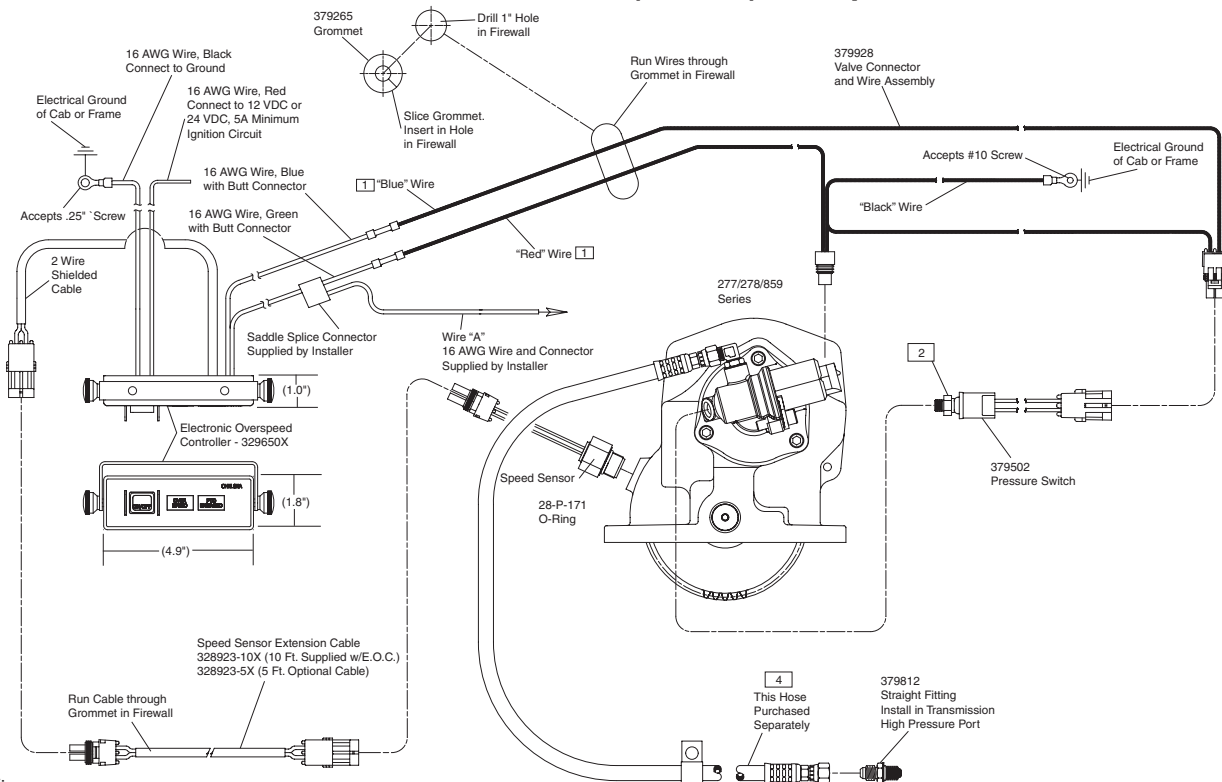

- NOTES:**
- 1) Strip Wire Ends .25" Prior to Installing in Butt Connector (As Necessary)
 - 2) Caution: Torque Values Must Be Maintained 120-144 Lb In
 - 3) Reference Kit: 329444X Installation Kit
 - 4) See Sk-414 For Hose Lengths

Remote Mount Installation Sketch for 277/278 Series (SK-413 Rev C) Caterpillar

329445-12X 12v Installation Kit
 329445-24X 24v Installation Kit

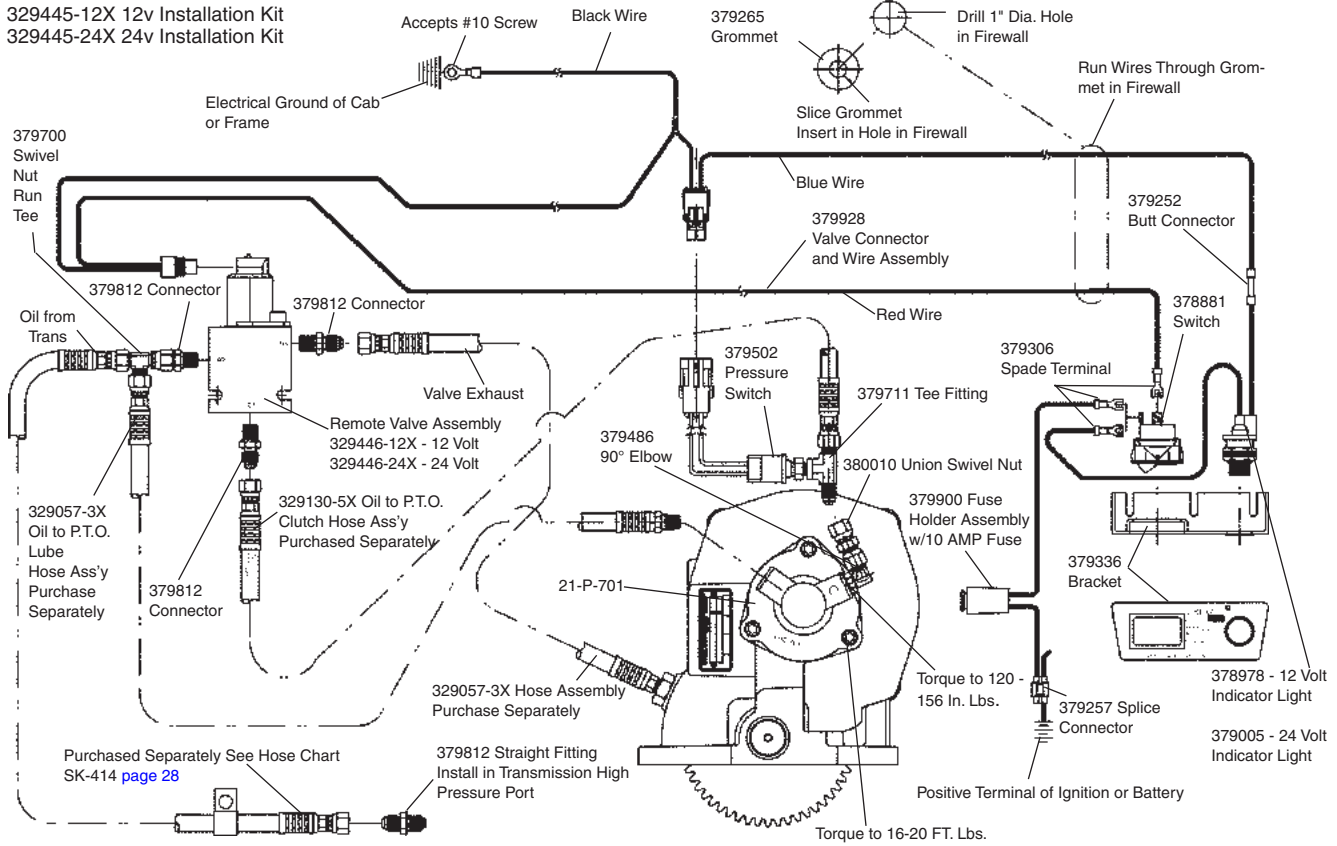

NOTE: This option is not available with, nor can it be used on E.O.C. applications.

Installation "AF" Wet Spline 277/278 Series (SK-383 Rev C) Allison & Caterpillar

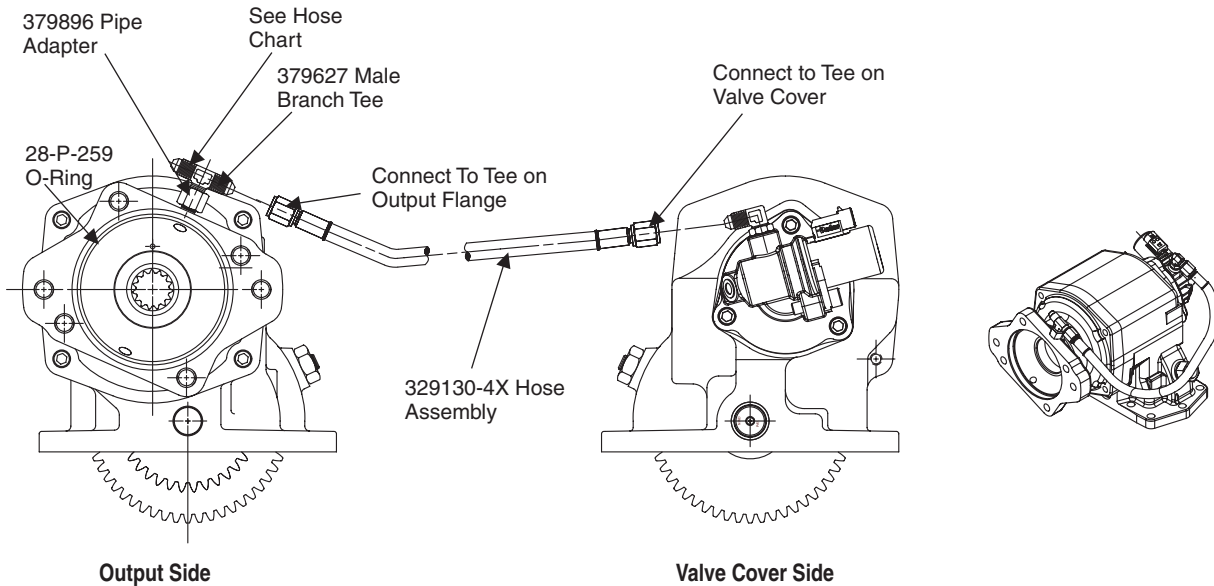

Pressure Hose Chart (Transmission to P.T.O.)		
Trans	Location	Hose
MD	Left	329130-1X
MD	Right	329075-1X
HD	Left	329130-1X
HD	Right	329075-2X

Pressure Port Locations & Hose Chart (SK-414 Rev B)

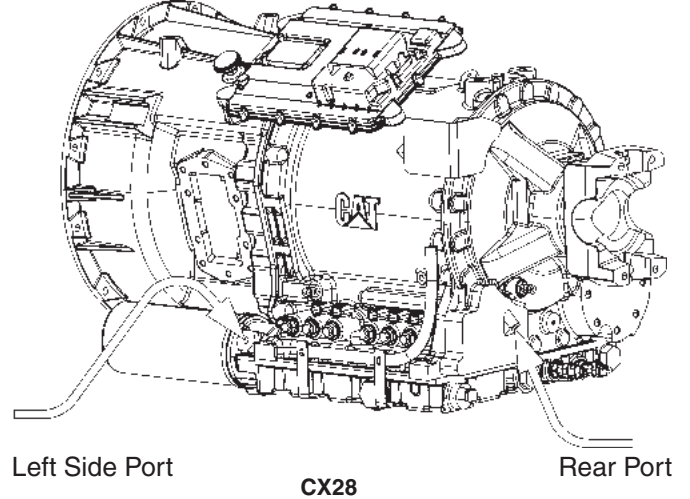
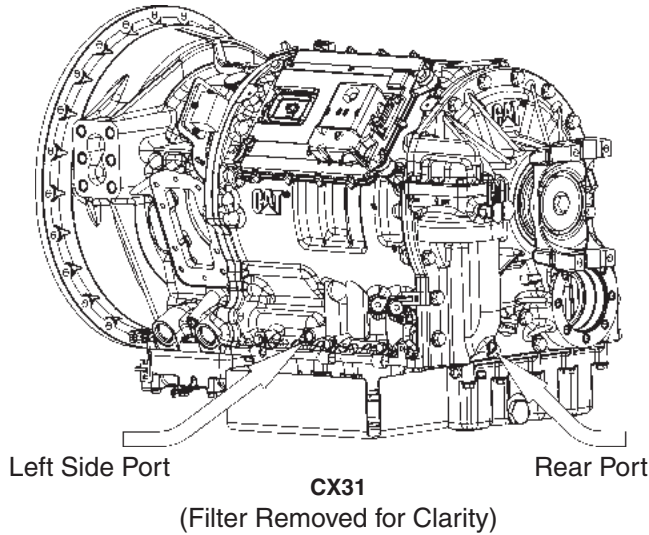

Both High Pressure Connections are -4 O-Ring Boss

HOSE CHART								
Trans.	P.T.O.	P.T.O. Location	High Oil Pressure Location	P.T.O. Valve Location	P.T.O. Fitting	Trans. Fitting	Trans.-P.T.O. Valve Hose #	
CX31 CX28	277, 278 859	Driver (LHS)	LHS	Attached	379486	379812	329075-1X	
		Driver (LHS)	Rear				329075-5X	
		Pass. (RHS)	LHS				329075-2X	
		Pass. (RHS)	Rear				329075-5X	
		Driver (LHS)	LHS	Remote	379486	379812	329130-6X	
		Driver (LHS)	Rear				329130-6X	
		Pass. (RHS)	LHS				329130-6X	
		Pass. (RHS)	Rear				329130-6X	
	267	Driver (LHS)	LHS	N/A	379486	379812	329130-3X	
			Rear				329075-5X	
			LHS				329075-2X	
			Rear				329075-5X	
		867	Driver (LHS)	LHS	N/A	379486	379812	329130-3X
				Rear				329075-5X
				LHS				329075-2X
				Rear				329075-5X

LHS = Left Side of Transmission, 8 o'clock position
RHS = Right Side of Transmission, 1 o'clock position

NOTES:

1. P.T.O. Fitting 379486 and Transmission Fitting 379812 included with the P.T.O. Unit. If Using 379486 in Transmission it Must be Purchased Separately.
2. Hoses to be Purchased Separately.
3. 379486 Elbow Will Not Install on the CX31 Left Hand (Driver) Side Oil Port Due to Transmission Interference. On CX28, 379486 Elbow will Fit on LHS Port.
4. If 379486 is Listed as Transmission Fitting for Rear Location for CX31. Route Hose Along Right Hand (passenger) Side of Transmission and Under Transmission Output Yoke. For the CX28, Route Hose Under the ECM.

Pressure Port and Aperture Opening Identification

1. These drawings represent left and right views of the MD and HD pressure ports on the transmission.

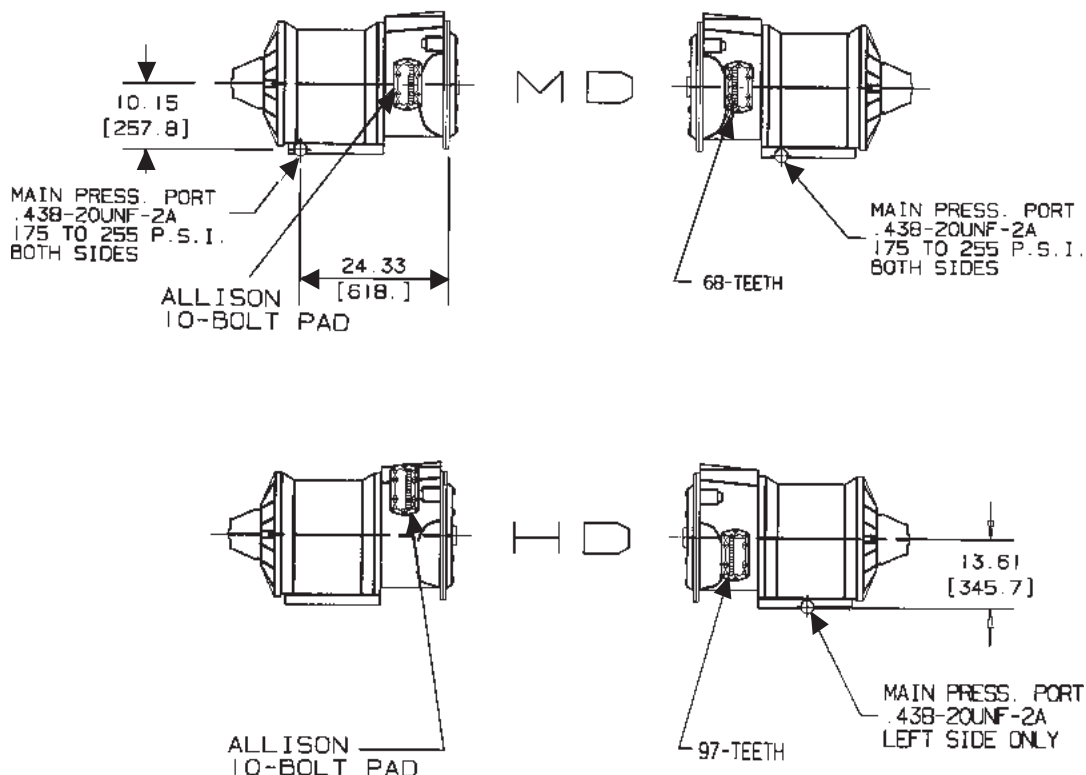

Hose Specifications by Transmission

TRANS.	LOCATION	277 Series	278 Series
MD	L.H. Side (Left Press. Port)	329130-5X	329130-5X
MD	R.H. Side (Right Press. Port)	329075-1X	329075-1X
HD	Top Right (Left Press. Port)	329075-2X	329075-2X
HD	L.H. Side (Left Press. Port)	329130-4X	329075-4X
HD ^{1,2}	L.H. Side (Left Press. Port)	329130-5X	329130-5X
HD ^{1,2}	Top Right (Right Press. Port)	329130-4X	329075-4X
MD ^{1,2}	L.H. Side (Left Press. Port)	329130-5X	329130-5X
MD ^{1,2}	R.H. Side (Right Press. Port)	329075-1X	329075-1X

An HD with 2 P.T.O.'s requires a 379556 "T" fitting and a 379703 swivel nut 90 degree elbow to attach 2 hoses to the single port on the left side.

1 Lubrication Option "R", shifter Options "G" and "H" for 277 Series

2 Lubrication Option "R" for 278 Series

Offer of Sale

The items described in this document and other documents or descriptions provided by Parker Hannifin Corporation, its subsidiaries and its authorized distributors are hereby offered for sale at prices to be established by Parker Hannifin Corporation, its subsidiaries and its authorized distributors. This offer and its acceptance by any customer ("Buyer") shall be governed by all of the following Terms and Conditions. Buyer's order for any such items, when communicated to Parker Hannifin Corporation, its subsidiary or an authorized distributor ("Seller") verbally or in writing, shall constitute acceptance of this offer.

1. Terms and Conditions of Sale: All descriptions, quotations, proposals, offers, acknowledgments, acceptances and sales of Seller's products are subject to and shall be governed exclusively by the terms and conditions stated herein. Buyer's acceptance of any offer to sell is limited to these terms and conditions. Any terms or conditions in addition to, or inconsistent with those stated herein, proposed by Buyer in any acceptance of an offer by Seller, are hereby objected to. No such additional, different or inconsistent terms and conditions shall become part of the contract between Buyer and Seller unless expressly accepted in writing by Seller. Seller's acceptance of any offer to purchase by Buyer is expressly conditional upon Buyer's assent to all the terms and conditions stated herein, including any terms in addition to, or inconsistent with those contained in Buyer's offer. Acceptance of Seller's products shall in all events constitute such assent.

2. Payment: Payment shall be made by Buyer net 30 days from the date of delivery of the items purchased hereunder. Amounts not timely paid shall bear interest at the maximum rate permitted by law for each month or portion thereof that the Buyer is late in making payment. Any claims by Buyer for omissions or shortages in a shipment shall be waived unless Seller receives notice thereof within 30 days after Buyer's receipt of the shipment.

3. Delivery: Unless otherwise provided on the face hereof, delivery shall be made F.O.B. Seller's plant. Regardless of the method of delivery, however, risk of loss shall pass to Buyer upon Seller's delivery to a carrier. Any delivery dates shown are approximate only and Seller shall have no liability for any delays in delivery.

4. Warranty: Seller warrants that certain Products, namely PTOs, SEMs, and Wet Line Kits sold hereunder shall be free from defects in material or workmanship for a period of twenty four months from the date of delivery to Buyer. Seller warrants that certain Products namely Pumps, and Hydraulic Accessories shall be free from defects in material or workmanship for a period of eighteen months from the date of delivery to the Buyer. The prices charged for Seller's products are based upon the exclusive limited warranty stated above, and upon the following disclaimer: **DISCLAIMER OF WARRANTY: THIS WARRANTY COMPRISES THE SOLE AND ENTIRE WARRANTY PERTAINING TO PRODUCTS PROVIDED HEREUNDER. SELLER DISCLAIMS ALL OTHER WARRANTIES, EXPRESS AND IMPLIED, INCLUDING MERCHANTABILITY AND FITNESS FOR A PARTICULAR PURPOSE.**

5. Limitation Of Remedy: SELLER'S LIABILITY ARISING FROM OR IN ANYWAY CONNECTED WITH THE ITEMS SOLD OR THIS CONTRACT SHALL BE LIMITED EXCLUSIVELY TO REPAIR OR REPLACEMENT OF THE ITEMS SOLD OR REFUND OF THE PURCHASE PRICE PAID BY BUYER, AT SELLER'S SOLE OPTION. IN NO EVENT SHALL SELLER BE LIABLE FOR ANY INCIDENTAL, CONSEQUENTIAL OR SPECIAL DAMAGES OF ANY KIND OR NATURE WHATSOEVER, INCLUDING BUT NOT LIMITED TO LOST PROFITS ARISING FROM OR IN ANYWAY CONNECTED WITH THIS AGREEMENT OR ITEMS SOLD HEREUNDER, WHETHER ALLEGED TO ARISE FROM BREACH OF CONTRACT, EXPRESS OR IMPLIED WARRANTY, OR IN TORT, INCLUDING WITHOUT LIMITATION, NEGLIGENCE, FAILURE TO WARN OR STRICT LIABILITY.

6. Changes, Reschedules and Cancellations: Buyer may request to modify the designs or specifications for the items sold hereunder as well as the quantities and delivery dates thereof, or may request to cancel all or part of this order, however, no such requested modification or cancellation shall become part of the contract between Buyer and Seller unless accepted by Seller in a written amendment to this Agreement. Acceptance of any such requested modification or cancellation shall be at Seller's discretion, and shall be upon such terms and conditions as Seller may require.

7. Special Tooling: A tooling charge may be imposed for any special tooling, including without limitation, dies, fixtures, molds and patterns, acquired to manufacture items sold pursuant to this contract. Such special tooling shall be and remain Seller's property notwithstanding payment of any charges by Buyer. In no event will Buyer acquire any interest in apparatus belonging to Seller which is utilized in the manufacture of the items sold hereunder, even if such apparatus has been specially converted or adapted for such manufacture and notwithstanding any charges paid by Buyer. Unless otherwise agreed, Seller shall have the right to alter, discard or otherwise dispose of any special tooling or other property in its sole discretion at any time.

8. Buyer's Property: Any designs, tools, patterns, materials, drawings, confidential information or equipment furnished by Buyer or any other items which become Buyer's property, may be considered obsolete and may be destroyed by Seller after two (2) consecutive years have elapsed without Buyer placing an order for the items which are manufactured using such property, Seller shall not be responsible for any loss or damage to such property while it is in Seller's possession or control.

9. Taxes: Unless otherwise indicated on the face hereof, all prices and charges are exclusive of excise, sales, use, property, occupational or like taxes which may be imposed by any taxing authority upon the manufacture, sale or delivery of the items sold hereunder. If any such taxes must be paid by Seller or if Seller is liable for the collection of such tax, the amount thereof shall be in addition to the amounts for the items sold. Buyer agrees to pay all such taxes or to reimburse Seller therefore upon receipt of its invoice. If Buyer claims exemption from any sales, use or other tax imposed by any taxing authority, Buyer shall save Seller harmless from and against any such tax, together with any interest or penalties thereon which may be assessed if the items are held to be taxable.

10. Indemnity For Infringement of Intellectual Property Rights: Seller shall have no liability for infringement of any patents, trademarks, copyrights, trade dress, trade secrets or similar rights except as provided in this Part 10. Seller will defend and indemnify Buyer against allegations of infringement of U.S. Patents, U.S. Trademarks, copyrights, trade dress and trade secrets (hereinafter 'Intellectual Property Rights'). Seller will defend at its expense and will pay the cost of any settlement or damages awarded in an action brought against Buyer based on an allegation that an item sold pursuant to this contract infringes the Intellectual Property Rights of a third party. Seller's obligation to defend and indemnify Buyer is contingent on Buyer notifying Seller within ten (10) days after Buyer becomes aware of such allegations of infringement, and Seller having sole control over the defense of any allegations or actions including all negotiations for settlement or compromise. If an item sold hereunder is subject to a claim that it infringes the Intellectual Property Rights of a third party, Seller may, at its sole expense and option, procure for Buyer the right to continue using said item, replace or modify said item so as to make it noninfringing, or offer to accept return of said item and return the purchase price less a reasonable allowance for depreciation. Notwithstanding the foregoing, Seller shall have no liability for claims of infringement based on information provided by Buyer, or directed to items delivered hereunder for which the designs are specified in whole or part by Buyer, or infringements resulting from the modification, combination or use in a system of any item sold hereunder. The foregoing provisions of this Part 10 shall constitute Seller's sole and exclusive liability and Buyer's sole and exclusive remedy for infringement of Intellectual Property Rights.

If a claim is based on information provided by Buyer or if the design for an item delivered hereunder is specified in whole or in part by Buyer, Buyer shall defend and indemnify Seller for all costs, expenses or judgments resulting from any claim that such item infringes any patent, trademark, copyright, trade dress, trade secret or any similar right.

11. Force Majeure: Seller does not assume the risk of and shall not be liable for delay or failure to perform any of Seller's obligations by reason of circumstances beyond the reasonable control of Seller (hereinafter 'Events of Force Majeure'). Events of Force Majeure shall include without limitation, accidents, acts of God, strikes or labor disputes, acts, laws, rules or regulations of any government or government agency, fires, floods, delays or failures in delivery of carriers or suppliers, shortages of materials and any other cause beyond Seller's control.

12. Entire Agreement/Governing Law: The terms and conditions set forth herein, together with any amendments, modifications and any different terms or conditions expressly accepted by Seller in writing, shall constitute the entire Agreement concerning the items sold, and there are no oral or other representations or agreements which pertain thereto. This Agreement shall be governed in all respects by the law of the State of Ohio. No actions arising out of the sale of the items sold hereunder or this Agreement may be brought by either party more than two (2) years after the cause of action accrues.

10/09-P



Parker Hannifin Corporation
Chelsea Products Division
8225 Hacks Cross Road
Olive Branch, Mississippi 38654 USA
Tel: (662) 895-1011
Fax: (662) 895-1069
www.parker.com/chelsea

TGI 03/11